

# *Rebel EMP 205ic AC/DC*

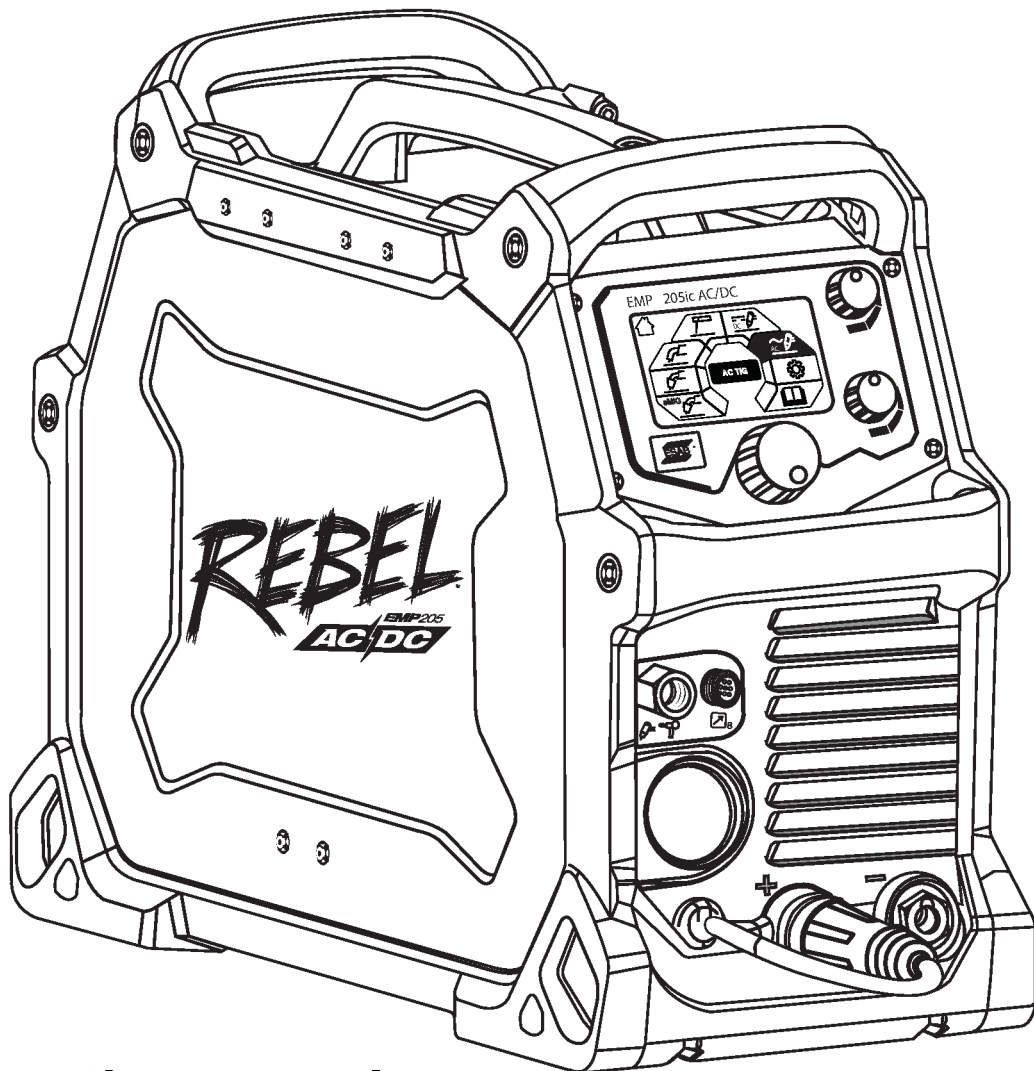

## Instruction manual

<b>1</b>	<b>SAFETY</b> .....	<b>4</b>
1.1	Meaning of symbols .....	4
1.2	Safety precautions .....	4
1.3	User responsibility .....	8
1.4	California Proposition 65 Warning.....	11
<b>2</b>	<b>INTRODUCTION</b> .....	<b>12</b>
2.1	Equipment .....	12
2.2	Overheating protection .....	12
<b>3</b>	<b>TECHNICAL DATA</b> .....	<b>13</b>
3.1	Rebel EMP 205ic AC/DC specifications .....	13
<b>4</b>	<b>INSTALLATION</b> .....	<b>15</b>
4.1	Location.....	15
4.2	High frequency interference .....	16
4.2.1	User's responsibility .....	16
4.2.2	Assessment of area.....	17
4.3	Lifting instructions .....	17
4.4	Main supply .....	18
4.5	Recommended fuse sizes and minimum cable area for Rebel EMP 205ic AC/DC .....	19
4.6	Supply from power generators .....	20
<b>5</b>	<b>OPERATION</b> .....	<b>21</b>
5.1	Connections .....	22
5.2	Connecting welding and return cables .....	23
5.2.1	For MMA/Stick/SMAW and TIG/GTAW process .....	23
5.2.2	For TIG/GTAW process .....	23
5.3	Polarity change .....	23
5.4	Shielding gas .....	24
5.5	Duty cycle .....	25
5.5.1	25% duty cycle .....	25
5.6	Installing spool .....	25
5.7	Installing and replacing wire .....	25
5.7.1	Installing wire .....	26
5.7.2	Removing wire .....	27
5.8	Welding with aluminum wire .....	30
5.9	Setting wire-feed pressure .....	30
5.10	Changing the feed/pressure rollers .....	31
<b>6</b>	<b>USER INTERFACE</b> .....	<b>34</b>
6.1	How to navigate .....	34
6.2	Main menu .....	34
6.3	sMIG mode: Basic .....	34
6.4	sMIG mode: Advanced .....	35

6.5	Manual MIG/MAG/GMAW mode: Basic .....	35
6.6	Manual MIG/MAG/GMAW mode: Advanced .....	35
6.7	Flux cored wire mode: Basic .....	35
6.8	Flux cored wire mode: Advanced .....	36
6.9	MMA/Stick/SMAW mode: Basic .....	36
6.10	MMA/Stick/SMAW mode: Advanced .....	36
6.11	DC TIG/GTAW mode: Basic .....	36
6.12	DC TIG/GTAW mode: Advanced .....	37
6.13	AC TIG/GTAW mode: Basic .....	37
6.14	AC TIG/GTAW mode: Advanced .....	37
6.15	Settings .....	38
6.16	User manual information .....	38
6.17	Icon reference guide .....	38
6.18	DC TIG/GTAW Pulse .....	41
6.19	AC TIG/GTAW Welding .....	44
6.20	Lift TIG / GTAW welding .....	48
<b>7</b>	<b>MAINTENANCE .....</b>	<b>50</b>
7.1	Routine maintenance .....	50
7.2	Wire-feeder assembly maintenance .....	51
7.2.1	Wire-feeder assembly cleaning .....	51
7.3	Rebel EMP 205ic AC/DC power side maintenance .....	52
7.4	Torch liner maintenance .....	53
7.4.1	Torch liner cleaning .....	53
<b>8</b>	<b>TROUBLESHOOTING .....</b>	<b>54</b>
8.1	Preliminary checks .....	54
8.2	User interface error codes .....	56
<b>9</b>	<b>ORDERING SPARE PARTS .....</b>	<b>57</b>
	<b>DIAGRAM .....</b>	<b>58</b>
	<b>ORDERING NUMBERS .....</b>	<b>59</b>
	<b>WEAR PARTS .....</b>	<b>60</b>
	<b>ACCESSORIES .....</b>	<b>62</b>
	<b>REPLACEMENTS PARTS .....</b>	<b>64</b>

# 1 SAFETY

## 1.1 Meaning of symbols

As used throughout this manual: Means Attention! Be Alert!



### DANGER!

Means immediate hazards which, if not avoided, will result in immediate, serious personal injury or loss of life.



### WARNING!

Means potential hazards which could result in personal injury or loss of life.



### CAUTION!

Means hazards which could result in minor personal injury.



### WARNING!

Before use, read and understand the instruction manual and follow all labels, employer's safety practices and Safety Data Sheets (SDSs).



## 1.2 Safety precautions



### WARNING!

These Safety Precautions are for your protection. They summarize precautionary information from the references listed in the Additional Safety Information section. Before performing any installation or operating procedures, be sure to read and follow the safety precautions listed below as well as all other manuals, material safety data sheets, labels, etc. Failure to observe Safety Precautions can result in injury or death.



### PROTECT YOURSELF AND OTHERS

Some welding, cutting and gouging processes are noisy and require hearing protection. The arc, like the sun, emits ultraviolet (UV) and other radiation and can injure the skin and eyes. Hot metal can cause burns. Training in the proper use of the processes and equipment is essential to prevent accidents. Therefore:

1. Wear a welding helmet fitted with a proper shade of filter to protect your face and eyes when welding or watching.
2. Always wear safety glasses with side shields in any work area, even if welding helmets, face shields and goggles are also required.
3. Use a face shield fitted with the correct filter and cover plates to protect your eyes, face, neck and ears from sparks and rays of the arc when operating or observing operations. Warn bystanders not to look at the arc and not to expose themselves to the rays of the electric-arc or hot metal.
4. Wear flameproof gauntlet-type gloves, heavy long-sleeve shirt, cuffless pants, high-topped shoes, and a welding helmet or cap for protection, to protect against arc rays and hot sparks or hot metal. A flameproof apron may also be desirable as protection against radiated heat and sparks.

5. Hot sparks or metal can lodge in rolled up sleeves, trouser cuffs, or pockets. Sleeves and collars should be kept buttoned and open pockets eliminated from the front of the clothing.
6. Protect other personnel from arc rays and hot sparks with a suitable non-flammable partition or curtains.
7. Use goggles over safety glasses when chipping slag or grinding. Chipped slag may be hot and can fly for long distances. Bystanders should also wear goggles over safety glasses.



### **FIRES AND EXPLOSIONS**

**The heat from flames and arcs can start fires. Hot slag or sparks can also cause fires and explosions. Therefore:**

1. Protect yourself and others from flying sparks and hot metal.
2. Move all combustible materials well away from the work area or cover the materials with a protective non-flammable covering. Combustible materials include wood, cloth, sawdust, liquid and gas fuels, solvents, paints, and coating paper, etc.
3. Hot sparks or hot metal can fall through cracks or crevices in floors or wall openings and cause a hidden smoldering fire or fires on the floor below. Make certain that such openings are protected from hot sparks and metal.
4. Do not weld, cut, or perform other hot work until the work piece has been completely cleaned so that there are no substances on the work piece which might produce flammable or toxic vapors. Do not perform hot work on closed containers, they may explode.
5. Have fire extinguishing equipment handy for instant use, such as a garden hose, water pail, sand bucket, or portable fire extinguisher. Be sure you are trained in its use.
6. Do not use equipment beyond its ratings. For example, an overloaded welding cable can overheat and create a fire hazard.
7. After completing work, inspect the work area to make sure there are no hot sparks or hot metal that could cause a fire later. Use fire watchers when necessary.



### **ELECTRICAL SHOCK**

**Contact between live electrical parts and earth can cause severe injury or death. DO NOT use AC welding current in damp areas, if movement is confined, or if there is danger of falling. Therefore:**

1. Be sure the power source frame (chassis) is connected to the earth system of the input power.
2. Connect the workpiece to a good electrical earth.
3. Connect the work cable to the workpiece. A poor or missing connection can expose you or others to a fatal shock.
4. Use well-maintained equipment. Replace worn or damaged cables.
5. Keep everything dry, including clothing, work area, cables, torch/electrode holder and power source.
6. Make sure that all parts of your body are insulated from both the work piece and from the ground.
7. Do not stand directly on metal or the ground while working in tight quarters or a damp area; stand on dry boards or an insulating platform and wear rubber-soled shoes.
8. Put on dry, hole-free gloves before turning on the power.
9. Turn off the power, before removing your gloves.
10. Refer to ANSI/ASC Standard Z49.1 for specific grounding recommendations. Do not mistake the work lead for a earth cable.



## ELECTRIC AND MAGNETIC FIELDS

**May be dangerous. Electric current flowing through any conductor causes localized Electric and Magnetic Fields (EMF). Welding and cutting current creates EMF around welding cables and welding machines. Therefore:**

1. Welders having pacemakers should consult their physician before welding. EMF may interfere with some pacemakers.
2. Exposure to EMF may have other health effects which are unknown.
3. Welders should use the following procedures to minimise exposure to EMF:
  - a) Route the electrode and work cables together. Secure them with tape when possible.
  - b) Never coil the torch or work cable around your body.
  - c) Do not place your body between the torch and work cables. Route cables on the same side of your body.
  - d) Connect the work cable to the workpiece as close as possible to the area being welded.
  - e) Keep welding power source and cables as far away from your body as possible.



## FUMES AND GASES

**Fumes and gases, can cause discomfort or harm, particularly in confined spaces. Shielding gases can cause asphyxiation. Therefore:**

1. Keep your head out of the fumes. Do not breathe the fumes and gases.
2. Always provide adequate ventilation in the work area by natural or mechanical means. Do not weld, cut or gouge on materials such as galvanized steel, stainless steel, copper, zinc, lead beryllium or cadmium unless positive mechanical ventilation is provided. Do not breathe in the fumes from these materials.
3. Do not operate near degreasing and spraying operations. The heat or arc can react with chlorinated hydrocarbon vapors to form phosgene, a highly toxic gas, and other irritant gases.
4. If you develop momentary eye, nose or throat irritation while operating, this is an indication that the ventilation is not adequate. Stop work and take the necessary steps to improve ventilation in the work area. Do not continue to operate if physical discomfort persists.
5. Refer to ANSI/ASC Standard Z49.1 for specific ventilation recommendations.



## CYLINDER HANDLING

**Cylinders, if mishandled, can rupture and violently release gas. A sudden rupture of cylinder valve or relief device can injure or kill. Therefore:**

1. Locate cylinders away from heat, sparks and flames. Never strike an arc on a cylinder.
2. Use the proper gas for the process and use the proper pressure reducing regulator designed to operate from the compressed gas cylinder. Do not use adapters. Maintain hoses and fittings in good condition. Follow the manufacturer's operating instructions for mounting a regulator to a compressed gas cylinder.
3. Always secure cylinders in an upright position, by chain or strap, to suitable hand trucks, undercarriages, benches, wall, post or racks. Never secure cylinders to work tables or fixtures where they may become part of an electrical circuit.
4. When not in use, keep cylinder valves closed. Have valve protection cap in place if regulator is not connected. Secure and move cylinders by using suitable hand trucks.



### MOVING PARTS

Moving parts, such as fans, rotors and belts can cause injury. Therefore:

1. Keep all doors, panels, guards, and covers closed and securely in place.
2. Have only qualified people remove covers for maintenance and troubleshooting as necessary
3. Keep hands, hair, loose clothing and tools away from moving parts.
4. Reinstall panels or covers and close doors when service is finished and before starting the unit.



#### WARNING!

#### FALLING EQUIPMENT CAN INJURE

- Only use lifting eye to lift unit. Do NOT use running gear, gas cylinders or any other accessories.
- Use equipment of adequate capacity to lift and support unit.
- If using lift forks to move unit, be sure forks are long enough to extend beyond opposite side of unit.
- Keep cables and cords away from moving vehicles when working from an aerial location.



#### WARNING!

#### EQUIPMENT MAINTENANCE

Faulty or improperly maintained equipment can cause injury or death.

Therefore:

1. Always have qualified personnel perform the installation, troubleshooting and maintenance work. Do not perform any electrical work unless you are qualified to perform such work.
2. Before performing any maintenance work inside a power source, disconnect the power source from the incoming electrical power.
3. Maintain cables, earthing wire, connections, power cord and power supply in safe working order. Do not operate any equipment in faulty condition.
4. Do not abuse any equipment or accessories. Keep equipment away from heat sources such as furnaces, wet conditions such as water puddles, oil or grease, corrosive atmospheres and inclement weather.
5. Keep all safety devices and cabinet covers in position and in good repair.
6. Use equipment only for its intended purpose. Do not modify it in any manner.

**CAUTION!****ADDITIONAL SAFETY INFORMATION**

**For more information on safe practices for electric arc welding and cutting equipment, ask your supplier for a copy of “Precautions and Safe Practices for Arc Welding, Cutting and Gouging,” Form 52-529.**

The following publications are recommended:

- ANSI/ASC Z49.1 - “Safety in Welding and Cutting”
- AWS C5.5 - “Recommended Practices for Gas Tungsten Arc Welding”
- AWS C5.6 - “Recommended Practices for Gas Metal Arc welding”
- AWS SP - “Safe practices” - Reprint, Welding Handbook
- ANSI/AWS F4.1 - “Recommended Safe Practices for Welding and Cutting of Containers That Have Held Hazardous Substances”
- OSHA 29 CFR 1910 - "Safety and health standards"
- CSA W117.2 - "Code for safety in welding and cutting"
- NFPA Standard 51B, “Fire Prevention During Welding, Cutting, and Other Hot Work”
- CGA Standard P-1, “Precautions for Safe Handling of Compressed Gases in Cylinders”
- ANSI Z87.1, "Occupational and Educational Personal Eye and Face Protection Devices"

### 1.3 User responsibility

Users of ESAB equipment have the ultimate responsibility for ensuring that anyone who works on or near the equipment observes all the relevant safety precautions. Safety precautions must meet the requirements that apply to this type of equipment. The following recommendations should be observed, in addition to the standard regulations that apply to the workplace.

All work must be carried out by trained personnel well-acquainted with the operation of the equipment. Incorrect operation of the equipment may lead to hazardous situations, which could result in injury to the operator and damage to the equipment.

1. Anyone who uses the equipment must be familiar with:
  - its operation
  - the location of emergency stops
  - its function
  - the relevant safety precautions
  - welding and cutting or other applicable operation of the equipment
2. The operator must ensure that:
  - no unauthorized person is within the working area of the equipment when it is started up
  - no-one is unprotected when the arc is struck or work is started with the equipment
3. The workplace must:
  - be suitable for the purpose
  - be free from drafts



4. Personal safety equipment:
  - Always wear recommended personal safety equipment, such as safety glasses, flame-proof clothing, safety gloves
  - Do not wear loose-fitting items, such as scarves, bracelets, rings, etc., which could become trapped or cause burns
5. General precautions:
  - Make sure the return cable is connected securely
  - Work on high voltage equipment **may only be carried out by a qualified electrician**
  - Appropriate fire extinguishing equipment must be clearly marked and close at hand
  - Lubrication and maintenance must **not** be carried out on the equipment during operation

**WARNING!**

Arc welding and cutting may cause injury to yourself and others. Take precautions when welding and cutting.

**ELECTRIC SHOCK - Can kill**

- Install and ground the unit in accordance with instruction manual.
- Do not touch live electrical parts or electrodes with bare skin, wet gloves, or wet clothing.
- Insulate yourself from work and ground.
- Ensure your working position is safe

**ELECTRIC AND MAGNETIC FIELDS - Pose health risks**

- Welders with pacemakers fitted should consult their doctor before welding. EMF may interfere with some pacemakers.
- Exposure to EMF may have other health effects which are unknown.
- Welders should use the following procedures to minimize exposure to EMF:
  - Route the electrode and work cables together on the same side of your body. Secure them with tape when possible. Do not place your body between the torch and work cables. Never coil the torch or work cable around your body. Keep the welding power source and cables as far away from your body as possible.
  - Connect the work cable to the workpiece as close as possible to the area being welded.

**FUMES AND GASES - Can be dangerous to your health**

- Keep your head out of the fumes.
- Use ventilation, extraction at the arc, or both, to take fumes and gases away from your breathing zone and the general area.

**ARC RAYS - Can injure eyes and burn skin**

- Protect your eyes and body. Use the correct welding screen and filter lens and wear protective clothing.
- Protect bystanders with suitable screens or curtains.

**NOISE - Excessive noise can damage hearing**

Protect your ears. Use ear defenders or other hearing protection.

**MOVING PARTS - Can cause injuries**



- Keep all doors, panels, guards, and covers closed and securely in place.
- Have only qualified people remove covers for maintenance and troubleshooting as necessary.



- Keep hands, hair, loose clothing and tools away from moving parts.
- Reinstall panels or covers and close doors when service is finished and before starting the unit.

**FIRE HAZARD**



- Sparks (spatter) can cause a fire. Make sure there are no inflammable materials nearby.
- Do not use on closed containers.

**HOT SURFACE - Parts can burn**



- Do not touch parts bare handed.
- Allow cooling period before working on equipment.
- To handle hot parts, use proper tools and/or insulated welding gloves to prevent burns.



**CAUTION!**

This product is solely intended for arc welding.



**CAUTION!**

Class A equipment is not intended for use in residential locations where the electrical power is provided by the public low-voltage supply system. There may be potential difficulties in ensuring electromagnetic compatibility of class A equipment in such locations, due to conducted as well as radiated disturbances.

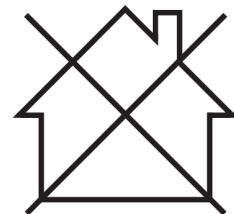

**NOTE!**

**Dispose of electronic equipment at the recycling facility!**

To conform with the European Directive 2012/19/EC on Waste Electrical and Electronic Equipment and its implementation in accordance with national law, electrical and/or electronic equipment that has reached the end of its life must be disposed of at a recycling facility.

As the person responsible for the equipment, it is your responsibility to obtain information on approved collection stations.

For further information contact the nearest ESAB dealer.

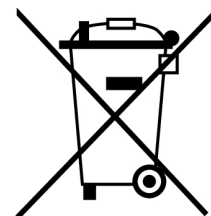

## 1.4 California Proposition 65 Warning



**WARNING!**

Welding or cutting equipment produces fumes or gases which contain chemicals known in the State of California to cause birth defects and, in some cases, cancer. (California Health & Safety Code Section 25249.5 et seq.)



**WARNING!**

This product can expose you to chemicals including lead, which are known to the state of California to cause cancer and birth defects or other reproductive harm. Wash hands after use.

For more information, go to [www.P65Warnings.ca.gov](http://www.P65Warnings.ca.gov).

**ESAB has an assortment of welding accessories and personal protection equipment for purchase. For ordering information, contact your local ESAB dealer or visit us on our website.**

---

## 2 INTRODUCTION

---

The Rebel EMP 205ic AC/DC product is a multi-process (MIG/Stick/GTAW: AC or DC) welding power source.

All Rebel power sources are designed to match the needs of the user. They are tough, durable, and portable, providing excellent arc performance across a variety of welding applications.

The EMP family features a 4.3 in. (11 cm) color TFT (Thin Film Transistor) user interface (UI) display which provides quick and easy selection of weld process and parameters, suitable for both newly trained and intermediate-level users. For more advanced users, any number of functions could be introduced and customized to give maximum flexibility.

**ESAB accessories for the product can be found in the "ACCESSORIES" chapter of this manual.**

### 2.1 Equipment

The Rebel EMP 205ic AC/DC power source is supplied with:

- Tweco® Fusion™ 180 A MIG torch 10 ft. (3 m), 8-pin connector, with 0.023", 0.030" and 0.035" (0.6 mm, 0.8 mm and 0.9 mm) contact tips and Allen key
- ESAB Heliarc SR 17 GTAW torch, 12.5 ft (3.8 m) with accessories
- Tweco® 200 A stick electrode holder with lead assembly, 13 ft (4 m), 50 mm OKC
- Tweco® 200 A work lead with clamp, 10 ft (3 m), 50 mm OKC
- 120/230 V power adapter
- Victor® flow meter with gas hose, 10 ft (3 m)
- Tweco remote foot control, 8-pin, 15 ft. (4.6 m)
- ESAB OK Aristorod 12.50, ER70S-6, 0.030" (0.8 mm), 2.2# (1 kg) spool of wire
- Drive Rolls for .023" (0.6 mm,) .030" (0.8 mm) and .035" (0.9 mm) wire diameter
- Outlet Guides .023" -.045" (0.6 mm -1.2 mm)
- Thickness Gage
- Welding chart (French)
- USB Stick includes manuals
- Quick Start Guide
- Instruction manual

### 2.2 Overheating protection

**CAUTION!**

This unit is equipped with overheating protection for its power supply.

The welding power source has overheating protection that operates if the internal temperature becomes too high. When this occurs, the welding current is interrupted, and an overheating symbol appears on the display. The overheating protection resets automatically when the temperature has returned to normal working temperature.

## 3 TECHNICAL DATA

### 3.1 Rebel EMP 205ic AC/DC specifications

	Rebel EMP 205ic AC/DC	
Voltage	120 V, 1 ph, 50/60 Hz	230 V, 1 ph, 50/60 Hz
<b>Primary current</b>		
$I_{max}$ . MIG/MAG/GMAW	Breaker 20 A: 27.1 A Breaker 15 A: 20.2 A	29.6 A
$I_{max}$ . DC TIG/GTAW	Breaker 15 A: 20.7 A	24.0 A
$I_{max}$ . AC TIG/GTAW	Breaker 15 A: 21.4 A	26.5 A
$I_{max}$ . MMA/Stick/SMAW	Breaker 15 A: 20.5 A	28.3 A
$I_{eff}$ . MIG/MAG/GMAW	Breaker 20 A: 15.8 A Breaker 15 A: 14.5 A	14.8 A
$I_{eff}$ . DC TIG/GTAW	Breaker 15 A: 14.3 A	12.0 A
$I_{eff}$ . AC TIG/GTAW	Breaker 15 A: 14.9 A	13.3 A
$I_{eff}$ . MMA/Stick/SMAW	Breaker 15 A: 14.4 A	14.1 A
<b>Permissible load at MIG/MAG/GMAW</b>		
100% duty cycle*	Breaker 15 A: 65 A/17.25 V Breaker 20 A: 70 A/17.5 V	110 A/19.5 V
60% duty cycle*	Breaker 15 A: 85 A/18.25 V Breaker 20 A: 90 A/18.5 V	125 A / 20.25 V
40% duty cycle*	Breaker 15 A: 90 A / 18.5 V	150 A / 21.5 V
25% duty cycle*	—	205 A/24.25 V
20% duty cycle*	Breaker 20 A: 115 A/19.75 V	—
<b>Setting range (DC)</b>	14.5 - 26.0 V	14.5 - 20.5 V
<b>Permissible load at DC TIG/GTAW</b>		
100% duty cycle*	Breaker 15 A: 80 A/13.2 V	110 A/14.4 V
60% duty cycle*	Breaker 15 A: 100 A/14.0 V	125 A/15.0 V
40% duty cycle*	Breaker 15 A: 110 A/14.4 V	—
25% duty cycle*	—	205 A/18.2 V
<b>Setting range (DC)</b>	5 – 130 A	5 - 205 A
<b>Permissible load at AC TIG/GTAW</b>		
100% duty cycle*	Breaker 15 A: 75 A/13.0 V	110 A/14.4 V
60% duty cycle*	Breaker 15 A: 95 A/13.8 V	125 A/15.0 V
40% duty cycle*	Breaker 15 A: 105 A/14.2 V	—
25% duty cycle*	—	205 A/18.2 V
<b>Setting range (DC)</b>	10 – 130 A	10 - 205 A
<b>Permissible load at MMA/Stick/SMAW</b>		
100% duty cycle*	55 A/22.2 V	100 A/24 V

<b>Rebel EMP 205ic AC/DC</b>		
60% duty cycle*	70 A/22.8 V	125 A/25 V
40% duty cycle*	75 A/23.0 V	—
25% duty cycle*	—	170 A/26.8 V
<b>Setting range (DC)</b>	16 A/20.6 V	16 A/20.6 V
	130 A / 25.2 V	180 A/27.2 V
<b>Open circuit voltage (OCV)</b>		
VRD deactivated	68 V	
VRD activated	< 35 V	
<b>Idle power</b>	34 W	
<b>Efficiency</b>	82 %	
<b>Power factor</b>	0.98	
<b>Wire feed speed</b>	80–475 in./min (2–12.1 m/min)	
<b>Wire diameter</b>		
Mild steel solid wire	0.023–0.035 in. (0.6–0.9 mm)	
Stainless steel solid wire	0.030–0.035 in. (0.8–0.9 mm)	
Flux-cored wire	0.030–0.045 in. (0.8–1.2 mm)	
Aluminum	0.030–3/64 in. (0.8–1.2 mm)	
<b>Bobbin size</b>	4–8 in. (100–200 mm)	
<b>Dimensions l × w × h</b>	23 × 9 × 16 in. (548 × 229 × 406 mm)	
<b>Weight</b>	50 lb. (22.7 kg)	
<b>Operating temperature</b>	14 to 104 °F (-10 to +40 °C)	
Enclosure class**	IP23S	
Application class***	S	

### Duty cycle

The duty cycle refers to the time as a percentage of a ten-minute period that you can weld or cut at a certain load without overloading. The duty cycle is valid for 104 °F (40 °C).

### Enclosure class

The **IP** code indicates the enclosure class, i.e. the degree of protection against penetration by solid objects or water.

Equipment marked **IP 23S** is intended for indoor and outdoor use; however, should not be operated in precipitation.

### Application class

The symbol **S** indicates that the power source is designed for use in areas with increased electrical hazard.

## 4 INSTALLATION

The installation must be carried out by a professional.



### CAUTION!

This product is intended for industrial use. In a domestic environment, this product may cause radio interference. It is the user's responsibility to take adequate precautions.



### CAUTION!

Remove any packaging material prior to use. Do not block the air vents at the front or rear of the welding power source.



### CAUTION!

Loose welding terminal connections can cause overheating and result in the male plug being fused in the terminal.

### 4.1 Location

Position the power source so that its cooling air inlets and outlets are not being obstructed.

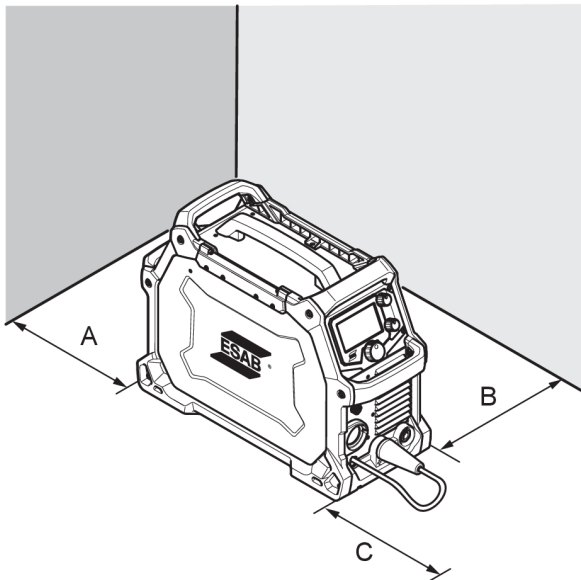

A. 8 in. (200 mm)

B. 8 in. (200 mm)

C. 8 in. (200 mm)

If permanent installation leave enough room to open door and access bobbin side.



### WARNING!

Secure the equipment - particularly if the ground is uneven or sloping.

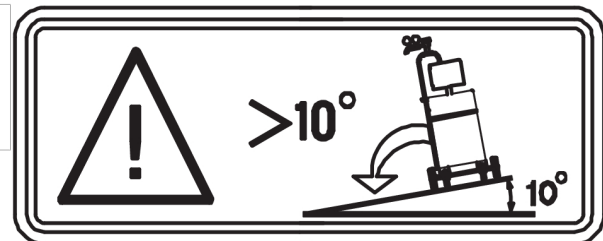

## 4.2 High frequency interference

**WARNING!**

The high frequency section of this machine has an output like a radio transmitter. The power source should NOT be used near blasting operations due to the danger of premature firing.

**WARNING!**

Operation close to computer installations may cause computer malfunction.

**WARNING!**

HIGH FREQUENCY FIELDS CAN BE DANGEROUS TO HEALTH. Extra precautions may be required when this welding power source is used in a domestic situation. Welders with medical pacemakers should consult their doctor before welding. EMF may interfere with some pacemakers.

**WARNING!**

The welding circuit may or may not be earthed for safety reasons. Changing the earthing arrangements should only be authorized by a person who is competent to assess whether the changes will increase the risk of injury, for example: by allowing parallel welding current return paths which may damage the earth circuits of other equipment.

**WARNING!**

Equipotential bonding:

Bonding of all metallic components in the welding installation and adjacent to it might be considered. However, metallic components bonded to the work piece will increase the risk that the operator could receive a shock by touching the metallic components and the electrode at the same time. The operator should be insulated from all such bonded metallic components.

**WARNING!**

Earthing/grounding of the work place:

Care should be taken to prevent the earthing of the work piece increasing the risk of injury to users, or damage to other electrical equipment. Changing the earthing arrangements should only be authorized by a person who is competent to assess whether the changes will increase the risk of injury.

**WARNING!**

The importance of correct installation of high frequency welding equipment cannot be overemphasized. Interference due to high frequency initiated or stabilized arc is almost invariably traced to improper installation. A duly authorized person such as a properly licensed electrician should perform the installation to avoid injury, death or any equipment damage.

### 4.2.1 User's responsibility

The user is responsible for installing and using the welding equipment according to the manufacturer's instructions. If electromagnetic disturbances are detected, then it shall be the



responsibility of the user of the welding equipment to resolve the situation with the technical assistance of the manufacturer. This remedial action may be as simple as earthing the welding circuit. In other cases, it could involve constructing an electromagnetic screen enclosing the welding power source and the work, complete with associated input filters. In all cases, electromagnetic disturbances shall be reduced to the point where they are no longer troublesome.

### 4.2.2 Assessment of area

Before installing welding equipment, the user shall assess potential electromagnetic problems in the surrounding area. The following shall be considered:

1. Other supply cables, control cables, signaling and telephone cables; above, below and adjacent to the welding equipment.
2. Radio and television transmitters and receivers.
3. Computer and other control equipment.
4. Safety critical equipment, e.g. guarding of industrial equipment.
5. The health of people around, e.g. the use of pacemakers and hearing aids.
6. Equipment used for calibration and measurement.
7. The time of day that welding or other activities are to be carried out.
8. The immunity of other equipment in the environment: the user shall ensure that other equipment being used in the environment is compatible: this may require additional protection measures.
9. The size of the surrounding area to be considered will depend on the structure of the building and other activities that are taking place. The surrounding area may extend beyond the boundaries of the premises.

Interference may be transmitted by a high frequency initiated or stabilized arc welding power source in the following ways:

- Direct radiation: Radiation from the equipment can occur if the case is metal and is not properly grounded. It can occur through apertures such as open access panels. The shielding of the high frequency unit in the power source will prevent direct radiation if the equipment is properly grounded.
- Transmission via the supply lead: Without adequate shielding and filtering, high frequency energy may be fed to the wiring within the installation (mains) by direct coupling. The energy is then transmitted by both radiation and conduction. Adequate shielding and filtering is provided in the power source.
- Radiation from welding leads: Radiated interference from welding leads, although pronounced near the leads, diminishes rapidly with distance. Keeping leads as short as possible will minimize this type of interference. Looping and suspending of leads should be avoided wherever possible.
- Re-radiation from unearthed metallic objects: A major factor contributing to interference is re-radiation from unearthed metallic objects close to the welding leads. Effective grounding of such objects will prevent re-radiation in most cases.

### 4.3 Lifting instructions

The power source can be lifted using any of the handles.

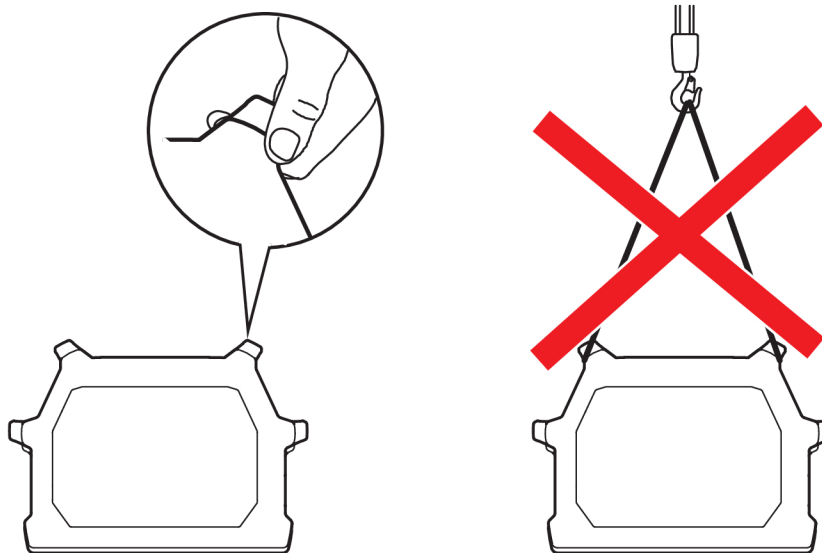

#### 4.4 Main supply



##### WARNING!

Contact the local electric utility for information about the type of electrical service available, how proper connections should be made, and inspection required.

The supply voltage should be 230 V AC  $\pm 10\%$  or 120 V AC  $\pm 10\%$ . Too low of supply voltage may cause poor welding performance. Too high supply voltage will cause components to overheat and possibly fail. Contact the local electric utility for information about the type of electrical service available, how proper connections should be made, and inspection required.

The welding power source must be:

- Correctly installed, if necessary, by a qualified electrician.
- Correctly grounded (electrically) in accordance with local regulations.
- Connected to the correct size power point and fuse as following table.



##### NOTE!

##### Mains supply requirements

This equipment complies with IEC 61000-3-12 provided that the short-circuit power is greater than or equal to  $S_{scmin}$  at the interface point between the user's supply and the public system. It is the responsibility of the installer or user of the equipment to ensure, by consultation with the distribution network operator if necessary, that the equipment is connected only to a supply with a short-circuit power greater than or equal to  $S_{scmin}$ .



##### NOTE!

Use the welding power source in accordance with the relevant national regulations.

1. Rating plate with supply connection data

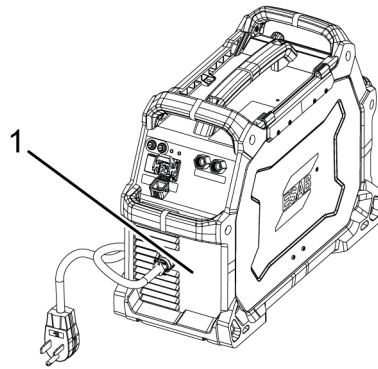

#### 4.5 Recommended fuse sizes and minimum cable area for Rebel EMP 205ic AC/DC



**WARNING!**

An electrical shock or fire hazard is probable if the following electrical service guide recommendations are not followed. These recommendations are for a dedicated branch circuit sized for the rated output and duty cycle of the welding power source.



**CAUTION!**

Disconnect input power and secure employing 'Lock-out/Tagging' procedures. Ensure input power line disconnect switch is locked (Lock-out/Tagging) in the 'Open' position BEFORE removing input power fuses. Connecting/disconnecting should be carried out by competent persons.

Rebel EMP 205ic AC/DC		
Supply voltage	120 V AC 1 P - 50/60 Hz	230 V AC 1 P - 50/60 Hz
<b>Maximum current rating (<math>I_{1max}</math>)</b> MMA/Stick/SMAW	30 A	33 A
<b>Maximum effective supply current (<math>I_{1eff}</math>)</b> MMA / Stick / SMAW	15.2 A	15.12 A
Maximum recommended fuse* or circuit breaker rating *Time delay fuse UL class RK5, refer to UL 248	30 A	40 A
Maximum recommended fuse* or circuit breaker rating Normal operating UL class K5, refer to UL 248	50 A	50 A
Mains supply cable	13 AWG (2.5 mm <sup>2</sup> )	13 AWG (2.5 mm <sup>2</sup> )
Maximum recommended extension cord length	25 ft (8 m)	50 ft (15 m)
Minimum recommended grounding conductor size	13 AWG (2.5 mm <sup>2</sup> )	13 AWG (2.5 mm <sup>2</sup> )

## **4.6 Supply from power generators**

The power source can be supplied from different types of generators. However, some generators may not provide sufficient power for the welding power source to operate correctly.

Generators with Automatic Voltage Regulation (AVR) or with equivalent or better type of regulation, with rated power of minimum 8 kW 1 phase, are recommended.

## 5 OPERATION

---

General safety regulations for handling the equipment can be found in the chapter "Safety." Read it before you start using the equipment.



**WARNING!**

Electric shock! Do not touch the workpiece or the welding head during operation!



**WARNING!**

Make sure that the side covers are closed during operation.



**WARNING!**

Tighten the bobbin bolt to prevent it from sliding off the hub.



**WARNING!**

Rotating parts can cause injury, take great care.



**NOTE!**

When moving the equipment, use the handle. Never pull the cables.

## 5.1 Connections

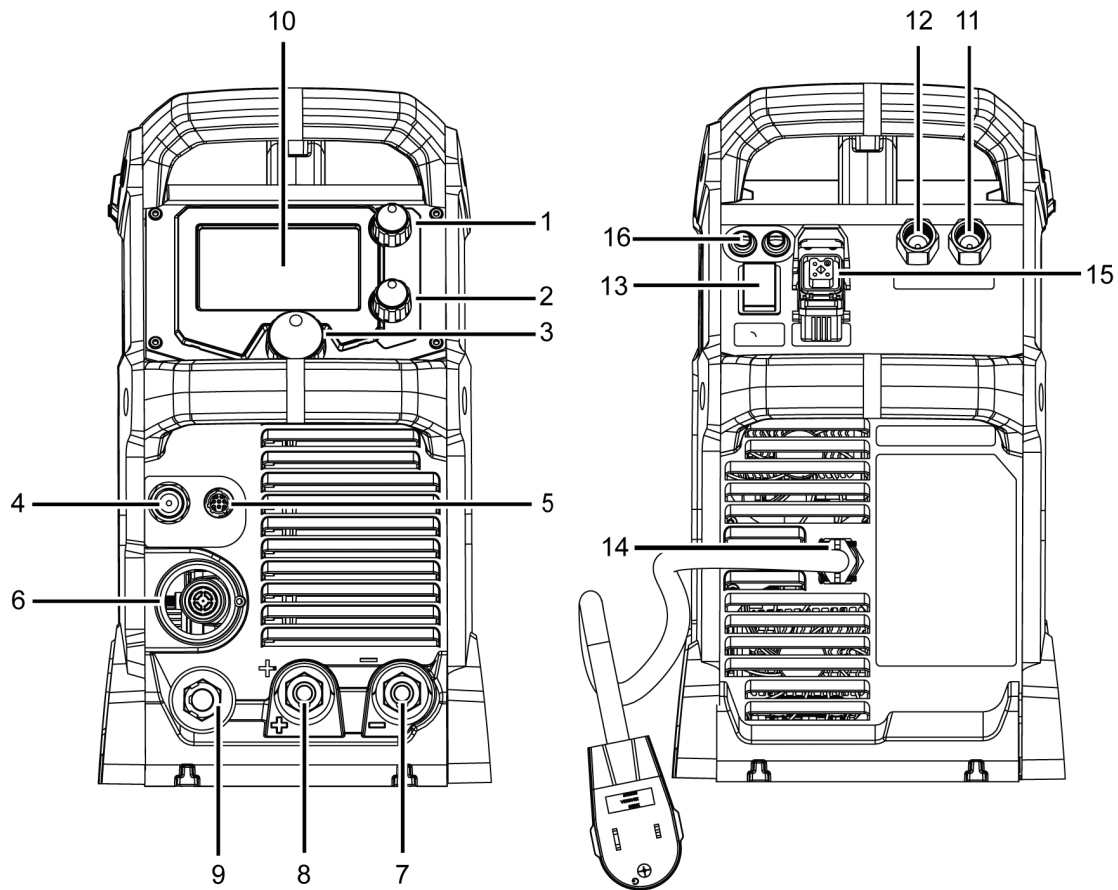

Front & rear views: Model Rebel EMP 205ic AC/DC

- |   |                                 |
|---|---------------------------------|
| 1. Encoder for current or wire-feed speed adjustment      | 9. Polarity changeover cable    |
| 2. Encoder for voltage adjustment                         | 10. Display                     |
| 3. Push button encoder (display navigation)               | 11. Gas inlet for MIG/MAG/GMAW  |
| 4. Gas outlet connection (TIG/GTAW)                       | 12. Gas inlet for TIG/GTAW      |
| 5. Torch trigger, remote and spool gun control receptacle | 13. Mains supply switch, ON/OFF |
| 6. MIG/MAG/GMAW torch and spool torch connection          | 14. Mains supply cable          |
| 7. Electrode negative terminal (-)                        | 15. 110/230 V cooler connection |
| 8. Electrode positive terminal (+)                        | 16. Fuses                       |



### NOTE!

Lower control knob (2) in MMA/Stick/SMAW mode turns output power ON/OFF. When output power is ON, background of display turns orange (see "[USER INTERFACE](#)", page 34).

## 5.2 Connecting welding and return cables

The power source has two outputs for connecting welding and return cables: a negative [-] terminal (7) and a positive [+] terminal (8) (see Figure 1).

### 5.2.1 For MMA/Stick/SMAW and TIG/GTAW process

For MMA/Stick/SMAW and TIG/GTAW process, the output to which the welding cable is connected depends on the type of electrode. Refer to electrode packaging for information relating to the correct electrode polarity. Connect the return cable to the remaining welding terminal (9) on the power source.

Secure the return cable's contact clamp to the work piece and ensure that there is good electrical contact. Connect the torch connector to the Torch connection (6).

### 5.2.2 For TIG/GTAW process

For TIG/GTAW process (requires optional TIG/GTAW accessories), connect the TIG/GTAW torch power cable to the negative [-] terminal (7), see illustration. Connect the gas inlet nut on the TIG/GTAW torch to the gas outlet connector (4) located on the front of the power source. Connect the gas inlet nut (12), on rear panel, to a regulated shielding gas supply. Connect the work return lead to the return-cable terminal (9). Connect the torch connector to the torch connection (6) (see Figure 1).

## 5.3 Polarity change

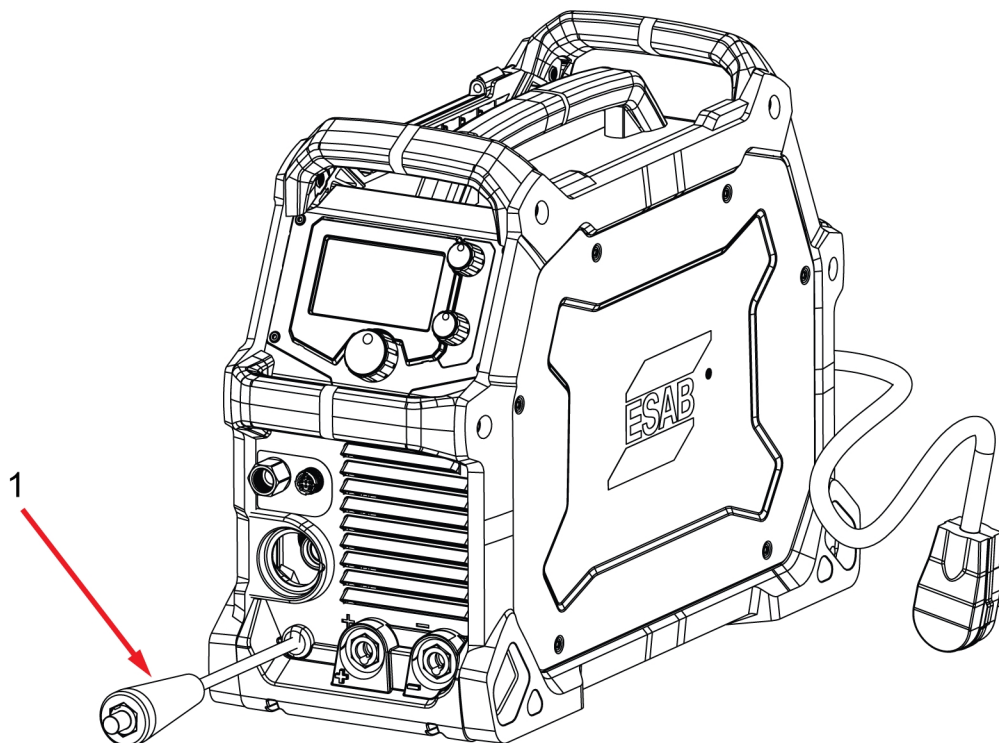

### *Polarity changeover connections*

#### 1. Polarity changeover cable

The polarity changeover cable is used to select the correct polarity for the weld output. The correct polarity is determined by the wire that has been selected to complete the weld. To configure the machine to operate with electrode positive, insert and secure the polarity changeover cable into the positive [+] terminal and the return lead into the negative [-] terminal. Be sure that the connections are tight. Secure the work clamp to the work piece in a

clean, debris-free location. Secure the work clamp to the work piece in a clean, debris free location.



**NOTE!**

For some wires it is recommended to use negative polarity such as self-shielded flux-core. See wire manufacturer's recommendation.

## 5.4 Shielding gas

The choice of suitable shielding gas depends on the material. Typically, mild steel is welded with mixed gas (Ar + CO<sub>2</sub>) or 100% carbon dioxide (CO<sub>2</sub>). Stainless steel can be welded with mixed gas (Ar + CO<sub>2</sub>) or trimix (He + Ar + CO<sub>2</sub>). Aluminum and silicon bronze use pure argon gas (Ar).



## 5.5 Duty cycle

### 5.5.1 25% duty cycle

The Rebel EMP 205ic AC/DC has a welding current output of 205 A at 25% duty cycle (230 V). A self-resetting thermostat will protect the power source if the duty cycle is exceeded.

**Example:** If the power source operates at a 25% duty cycle, it will provide the rated amperage for a maximum of 2.5 minutes out of every 10-minute period. The remaining time, 7.5 minutes, the power source must be allowed to cool down.

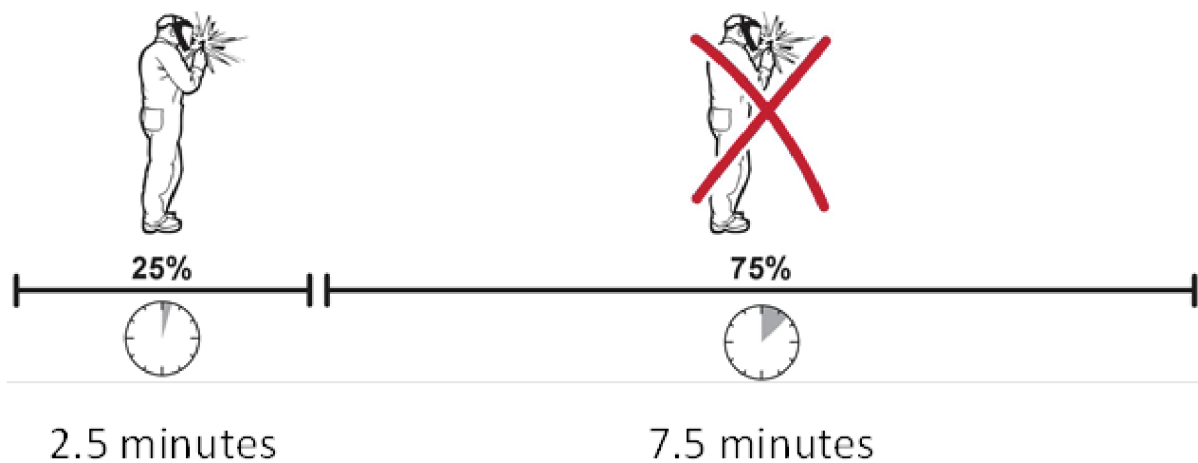

## 5.6 Installing spool

The spring sets the "braking value" working against the wire-feed motor and the pull of the roller-feed wheels. Tighten the bolt "A", see illustrations below, hand tight.

Remove/Install the bobbin as shown in below.

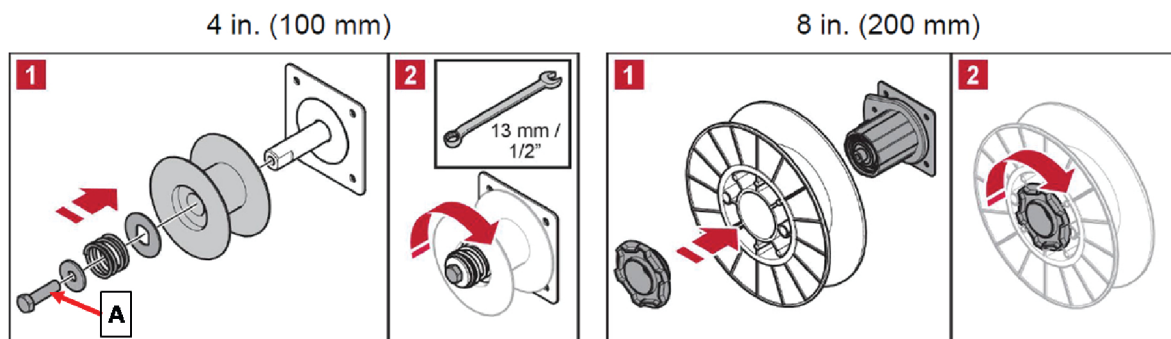

*Tightening the bobbin locking nut for 4 in. (100 mm)*

A. Bobbin locking nut

## 5.7 Installing and replacing wire



### NOTE!

If installing aluminum wire, see "Welding with aluminum wire" section.

The Rebel EMP 205ic AC/DC will handle bobbin sizes of 4 in. (100 mm), and 8 in. (200 mm). See "TECHNICAL DATA" chapter for suitable wire dimensions for each wire type.

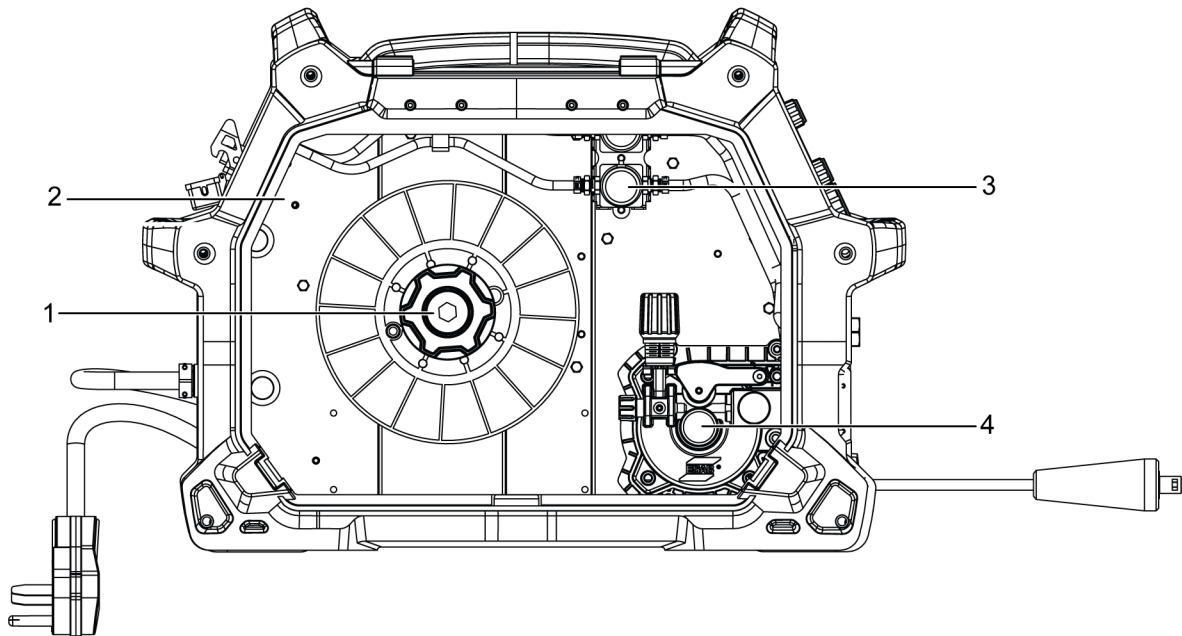

*View of wire-bobbin side*

- |                      |                       |
|----------------------|-----------------------|
| 1. Wire-bobbin shaft | 3. Gas valves         |
| 2. Circuit breaker   | 4. Wire-feed assembly |



**WARNING!**

Do not place or point the torch near the face, hand or body as this may result in injury.



**NOTE!**

Make sure the correct wire-feed rollers are selected.



**NOTE!**

Use the correct contact tip in the welding torch for the wire diameter used.

### 5.7.1 Installing wire

1. Disconnect the electrical power source from the unit.
2. Open the wire-bobbin side cover of the unit.
3. Install the new bobbin (see "Removing/installing bobbin" section).
4. On the wire-feed assembly release the tension arm by pulling the tension knob up out of its detent and rotating it toward you. The tension arm is spring-loaded.
5. Install drive rolls for selected wire size.
6. With a clean-cut pull, the wire from the bobbin and feed wire into the inlet guide and through the wire-feed assembly until it extend out of the torch connector about 2.0 in. (50 mm).
7. Close the tension-arm onto the wire in its groove on the drive rolls.
8. Re-connect the torch assembly to the unit being careful to insert the end of the wire protruding from the outlet guide into the torch connector.
9. Power up the unit.

10. With the torch cable laid out reasonably straight, feed the wire through the torch cable until it is visible at its welding tip by depressing the trigger switch on the torch.
11. To more accurately set and verify the wire-feed tension for correct feed pressure, see "Setting wire-feed pressure" section.
12. Close the cover on the wire-bobbin side of the unit.

### 5.7.2 Removing wire

1. Disconnect the electrical power source from the unit.
2. Open the wire-bobbin side cover of the unit and observe how the wire feeds from the bobbin, through the wire feed assembly and into the torch connection.

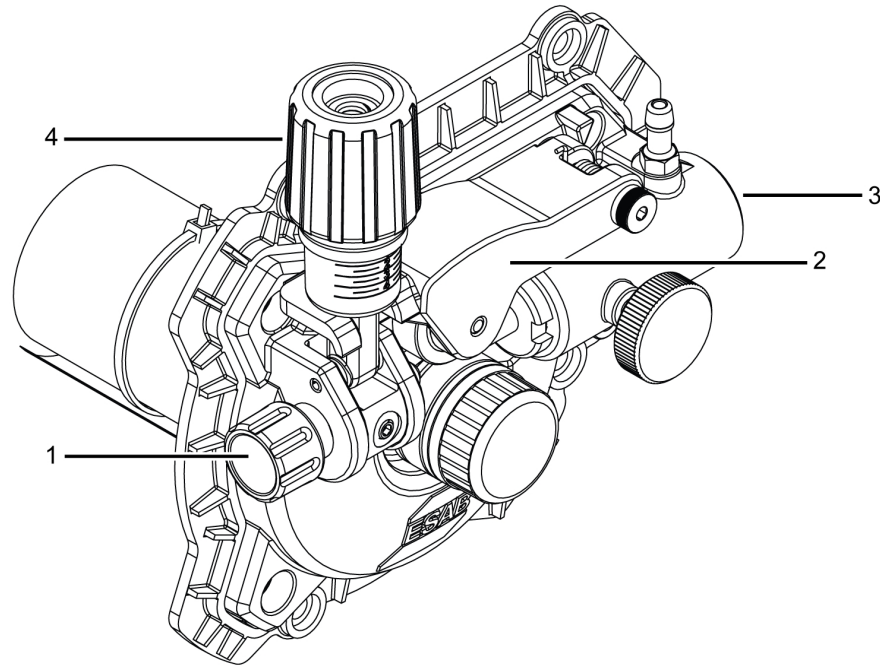

#### *Path of wire through wire feed assembly*

- |                     |                          |
|---------------------|--------------------------|
| 1. Wire from bobbin | 3. Wire to torch         |
| 2. Pressure arm     | 4. Tension knob assembly |

3. Locate the wire-feed assembly and its tension-knob.

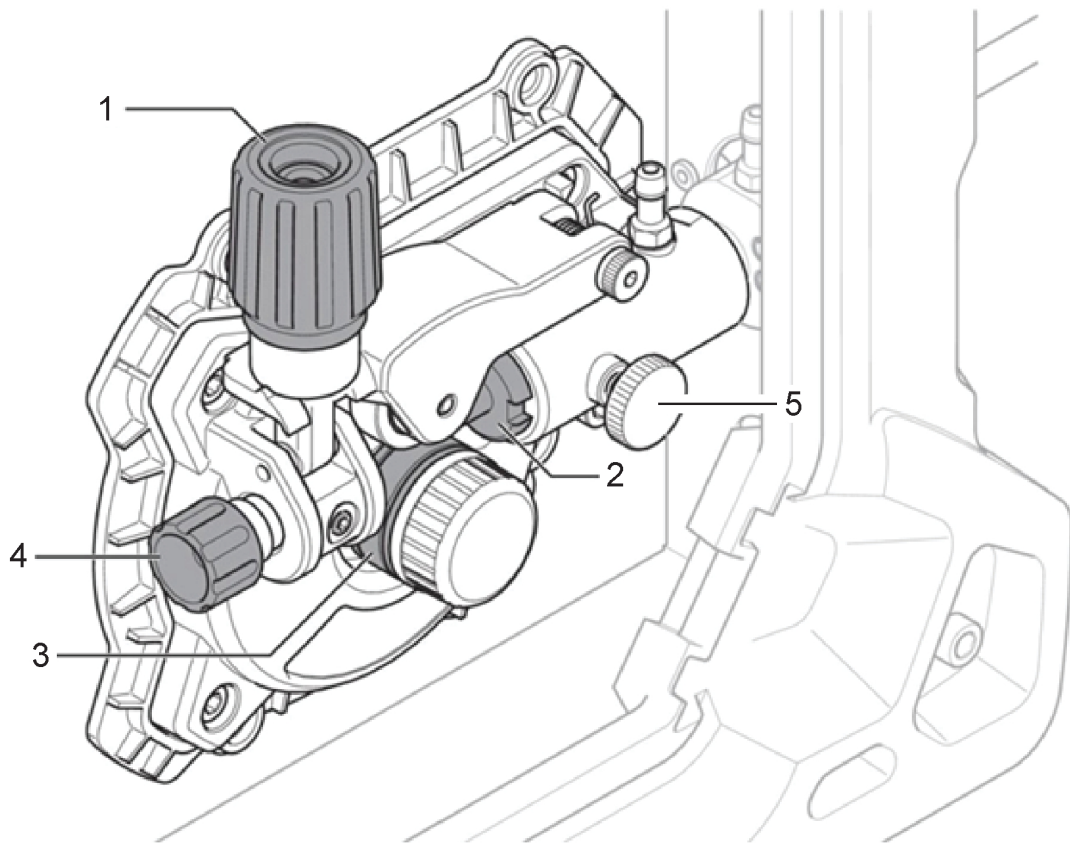

*Wire-feed assembly part names*

- |                      |                                    |
|----------------------|------------------------------------|
| 1. Tension knob      | 4. Inlet wire-guide                |
| 2. Outlet wire-guide | 5. MIG/MAG/GMAW torch locking knob |
| 3. Wire-feed roller  |                                    |

- On the wire-feed assembly release the tensioning arm by partially unscrewing the tension knob, pulling it up out of its detent and rotating it toward you.

**NOTE!**

The tensioning arm is spring-loaded. It will pop-up when the tension knob is rotated out-of-the-way.

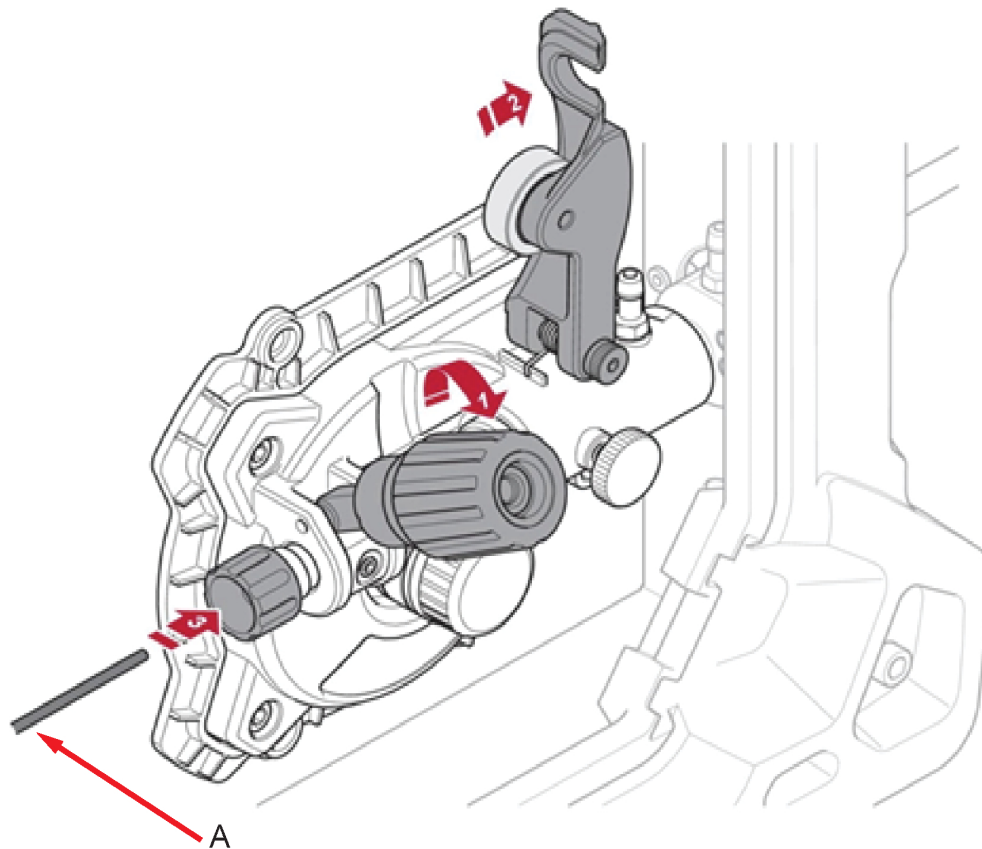
*Wire-feed mechanism*

A. Wire in from bobbin

- If wire remains in the torch assembly:**  
Near the inlet wire-guide on the wire-feed assembly cut the wire while holding the bobbin-end, so the wire does not unravel from the bobbin after cutting it loose. Secure the cut end of the wire to the bobbin to prevent the wire from unraveling from the bobbin.
- If wire remains in the torch assembly:**  
Disconnect the torch assembly from the unit by loosening the MIG/MAG/GMAW torch locking knob.
- Pull the remaining length of the wire through the wire-feed assembly and, with the torch, set the torch assembly aside (with the loose wire still installed in the torch). The old wire should now be completely removed from the wire-feed assembly.
- Pull the length of old wire out of the torch assembly from either end of the torch assembly.
- Remove the bobbin from the unit.

## 5.8 Welding with aluminum wire



### NOTE!

Make sure to use the correct contact tip in the welding torch for the wire diameter used. The torch is fitted with a contact tip for 0.030 in. (0.8 mm) wire. If you use another diameter, make sure to change the contact tip and drive roll. The wire liner fitted in the torch is recommended for welding with Fe and SS wires.

To weld aluminum using the standard supplied torch, refer to MIG torch instruction manual for replacing standard steel torch conduit liner with a teflon torch conduit liner.

To GMAW weld with aluminum wire, use optional spool gun for the best result. Refer to Spool Gun Instruction Manual for the correct set up.

## 5.9 Setting wire-feed pressure



### CAUTION!

Overtension of the brake will cause rapid wear of mechanical wire feeder parts, overheating of electrical components and possibly more incidences of contact tip burnback.

1. Start by making sure that the wire moves smoothly through the wire guide. Then set the pressure of the wire feeder's pressure rollers. It is important that the pressure is not too high.
2. To check that the feed pressure is set correctly, you can feed out the wire against an insulated object, e.g. a piece of wood.
3. When you hold the welding torch approximately 0.2 in. (5 mm) from the piece of wood, the feed rollers should slip.
4. If you hold the welding torch approximately 2 in. (50 mm) from the piece of wood, the wire should be fed out and bend.

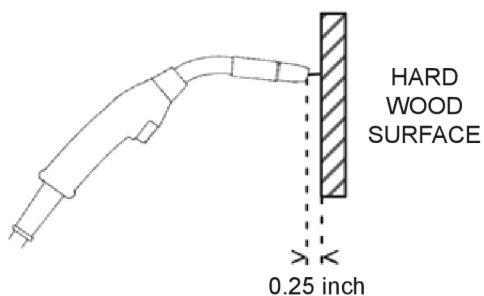

*Check feed-roller for slip, indicating no over-pressure*

- The wire reel hub incorporates a friction brake which is adjusted during manufacture for optimum braking. If it is considered necessary, adjustment can be made by turning the thumb screw inside the open end of the hub clockwise to tighten the brake. Correct adjustment will result in the wire reel circumference continuing no further than 1/8 in.-3/16 in. (3-5 mm) after release of the trigger. The electrode wire should be slack without becoming dislodged from wire spool.

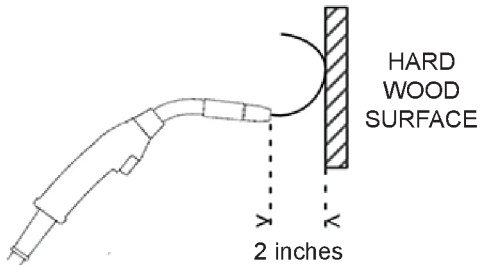

*Checking for proper feed-roller pressure*

## 5.10 Changing the feed/pressure rollers



### **NOTE!**

Make sure not to lose the key that is located on the drive motor shaft. This key must be in place and align with drive roll slot for proper operation.

Three dual groove feed roller are supplied as standard. Change the feed roller to match the filler metal wire diameter.

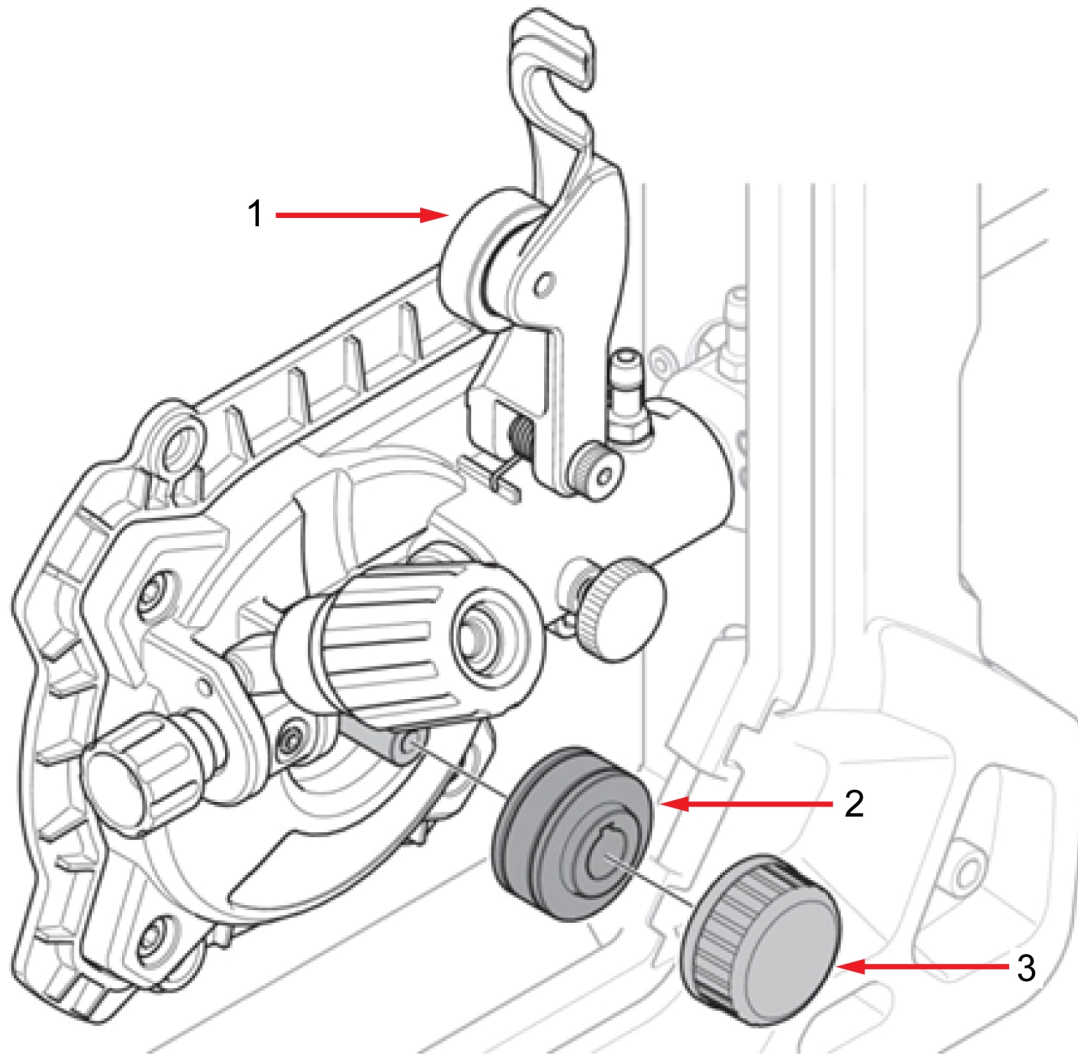

*Location of wire-feed rollers and pressure rollers*

- |                     |                 |
|---------------------|-----------------|
| 1. Pressure roller  | 3. Locking knob |
| 2. Wire-feed roller |                 |

1. Open the spool side door.
2. Release the pressure roller arm by levering the tension screw.
3. Lift the pressure roller arm.
4. Remove the feed roll retaining screw by turning it counterclockwise.
5. Change the feed roll.
6. Tighten the feed roll retaining screw by turning it clockwise.
7. Secure the pressure roller arm and wire drive tension screw.
8. Close the spool side door.



**NOTE!**

Visual indication on the face of the drive roll indicates the diameter of the groove on the outside of the drive roll and the groove that is in use for the selected wire diameter.



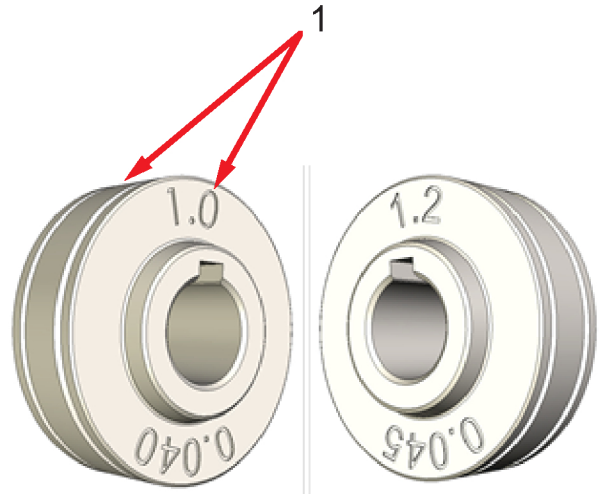

*Wire-feed rollers offered in multiple sizes*

- 1. Labels

## 6 USER INTERFACE

General safety regulations for handling the equipment can be found in the "Safety precautions" section in the "SAFETY" chapter of this manual. General information about operation can be found in the "OPERATION" chapter of this manual. Read both chapters thoroughly before you start using the equipment!



### NOTE!

After power-on has completed, the main menu appears on the user interface.

### 6.1 How to navigate

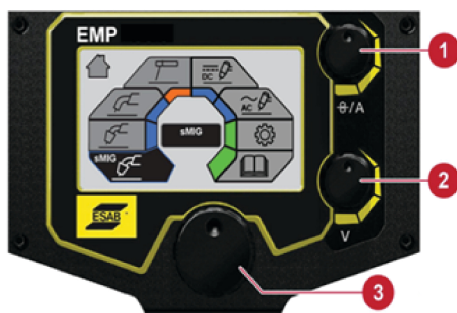

1. Upper encoder
  - a) Set current output value
  - b) Set wire-feed speed
2. Lower encoder
  - a) MIG/MAG/GMAW Voltage Selection
  - b) sMIG Voltage Trim
  - c) MMA/Stick/SMAW Mode: ARC ON/OFF
  - d) DC TIG/GTAW: Set PPS
  - e) AC TIG/GTAW: Set Balance
3. Menu navigation: Push button encoder

### 6.2 Main menu

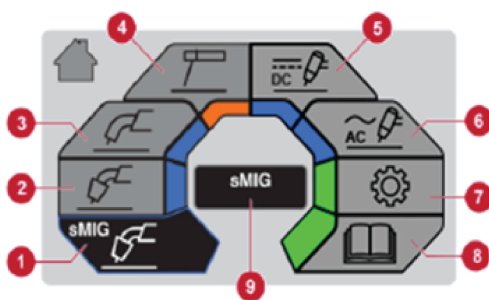

1. sMIG mode
2. Manual MIG/MAG/GMAW mode
3. Flux-cored wire mode
4. MMA/Stick/SMAW mode
5. DC TIG/GTAW mode
6. AC TIG/GTAW mode
7. Settings
8. User manual
9. Dialogue box

### 6.3 sMIG mode: Basic

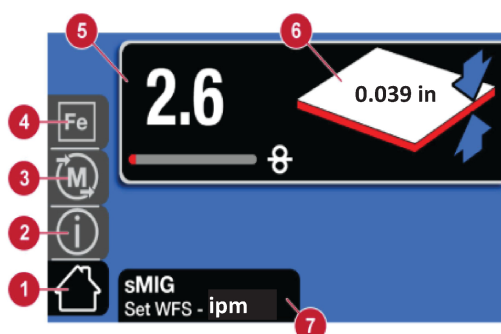

1. Home screen selection
2. Information
3. Memory
4. Material selection
5. Wire-feed speed indication
6. Material thickness indication
7. Dialogue box

### 6.4 sMIG mode: Advanced

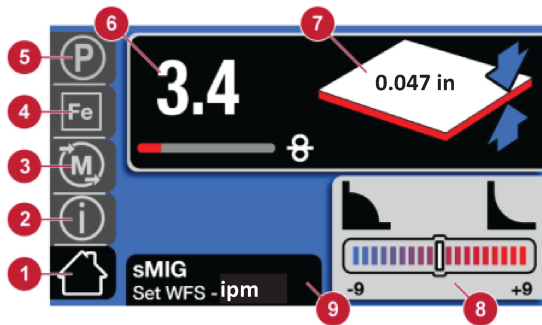

1. Home screen selection
2. Information
3. Memory
4. Material selection
5. Weld variables
6. Wire-feed speed indication
7. Material thickness indication
8. Voltage trim indication
9. Dialogue box

### 6.5 Manual MIG/MAG/GMAW mode: Basic

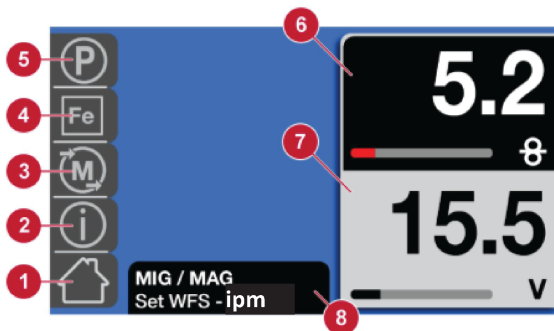

1. Home screen selection
2. Information
3. Memory
4. Material selection
5. Weld variables
6. Wire-feed speed indication
7. Voltage indication
8. Dialogue box

### 6.6 Manual MIG/MAG/GMAW mode: Advanced

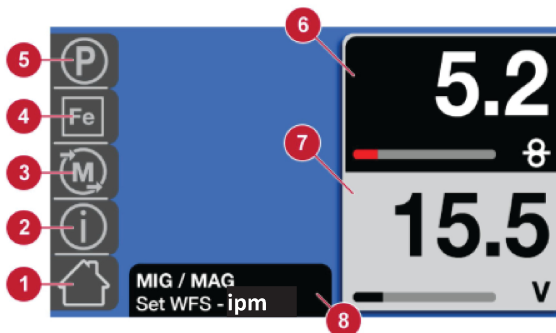

1. Home screen selection
2. Information
3. Memory
4. Material selection
5. Weld variables
6. Wire-feed speed indication
7. Voltage indication
8. Dialogue box

### 6.7 Flux cored wire mode: Basic

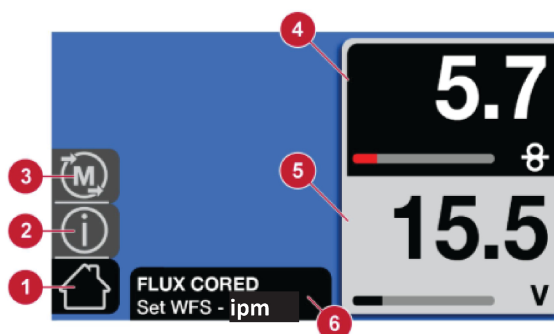

1. Home screen selection
2. Information
3. Memory
4. Wire-feed speed indication
5. Voltage indication
6. Dialogue box

### 6.8 Flux cored wire mode: Advanced

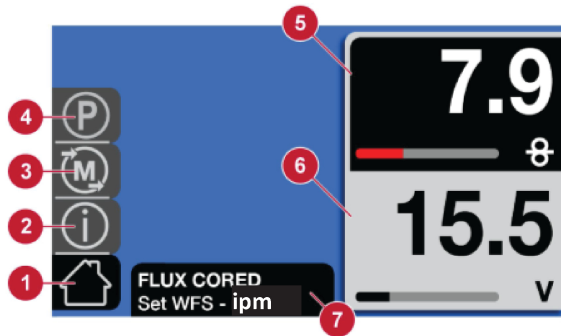

1. Home screen selection
2. Information
3. Memory
4. Weld variables
5. Wire-feed speed indication
6. Voltage indication
7. Dialogue box

### 6.9 MMA/Stick/SMAW mode: Basic

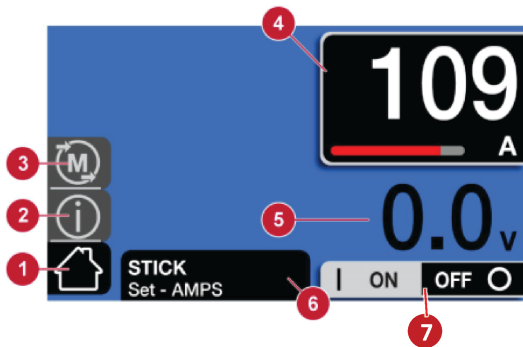

1. Home screen selection
2. Information
3. Memory
4. Amperage indication
5. Power-supply output voltage
6. Dialogue box
7. Output ON/OFF indication

Blue user interface background will change to orange when the output is "Hot/ON."

### 6.10 MMA/Stick/SMAW mode: Advanced

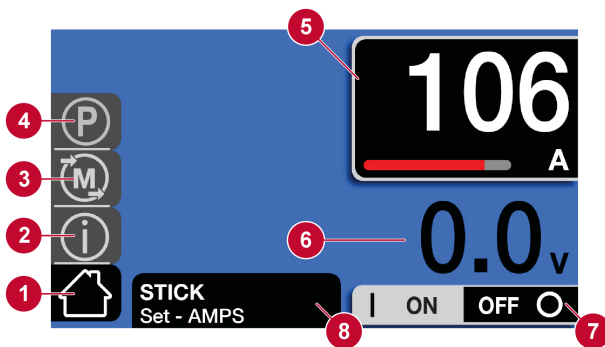

1. Home screen selection
2. Information
3. Memory
4. Weld variables
5. Amperage indication
6. Power-supply output voltage
7. Output ON/OFF indication
8. Dialogue box

Blue user interface background will change to orange when the output is "Hot/ON."

### 6.11 DC TIG/GTAW mode: Basic

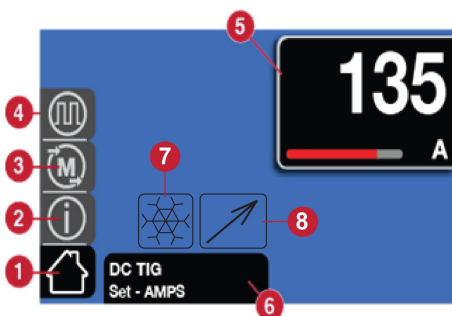

1. Home screen selection
2. Information
3. Memory
4. Pulse ON/OFF section and pulse weld variables
5. Amperage indication
6. Dialogue box
7. Cooler connected indicator
8. Remote connected indicator

### 6.12 DC TIG/GTAW mode: Advanced

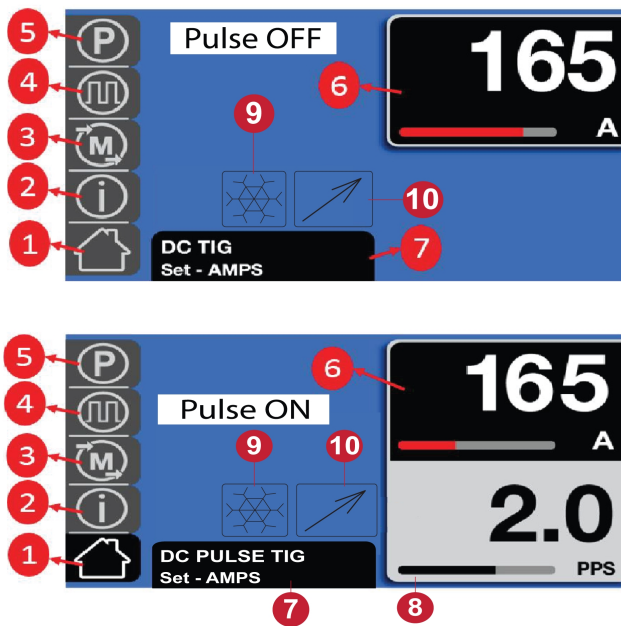

1. Home screen selection
2. Information
3. Memory
4. Pulse ON/OFF section and pulse weld variables
5. Weld variables
6. Amperage indication
7. Dialogue box
8. Pulses per second indication
9. Cooler connected indicator
10. Remote connected indicator

### 6.13 AC TIG/GTAW mode: Basic

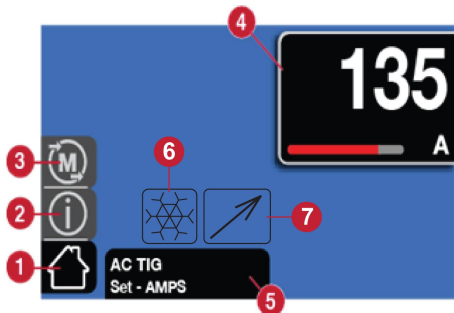

1. Home screen selection
2. Information
3. Memory
4. Amperage indication
5. Dialogue box
6. Cooler connected indicator
7. Remote connected indicator

### 6.14 AC TIG/GTAW mode: Advanced

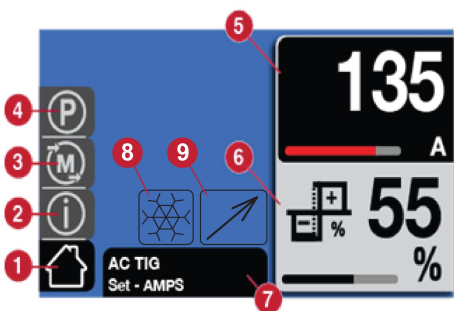

1. Home screen selection
2. Information
3. Memory
4. Weld variables
5. Amperage indication
6. Balance indication
7. Dialogue box
8. Cooler connected indicator
9. Remote connected indicator

### 6.15 Settings

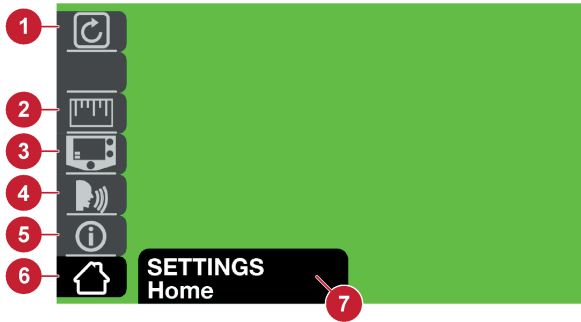

- 1. Reset mode selection
- 2. Unit of measure selection
- 3. Basic or advanced selection
- 4. Language selection
- 5. Information
- 6. Home screen selection
- 7. Dialogue box

### 6.16 User manual information



- 1. Maintenance information
- 2. Wear part information
- 3. Operation information
- 4. Home screen selection
- 5. Dialogue box





















### 6.17 Icon reference guide











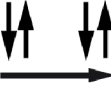

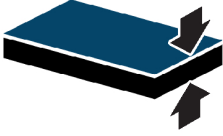







**NOTE!**





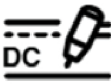



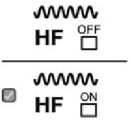
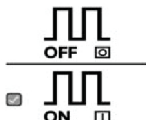

SCT – Short Circuit Termination is a method of automatic burn back at the end of the weld to electrically cut the wire by pulsing high current in a controlled process. The result is a nice clean wire end with no balling or sticking to the weld pool or tip. This allows exceptional restarting of subsequent welds. This feature is primarily for Mild and Stainless steel short-arc welding. For spray and flux core welding, traditional burn back is recommended. When burn back time is set to zero, SCT automatically is enabled. A non-zero burn back setting will disable SCT.

ICON	MEANING	ICON	MEANING
	Home		Spot time on/off selection
	Burn back time		Short Circuit Termination

ICON	MEANING	ICON	MEANING
	Information		Wire feed speed
	MIG/MAG/GMAW Torch		Spot time on adjustment
	Parameters		Flux cored
	Parameters		Manual MIG/MAG/GMAW
	Percent		MMA/Stick/SMAW
	Pre-flow time		Smart MIG/MAG/GMAW
	Post-flow time		Lift TIG/GTAW
	Seconds		Saving
	Settings		Cancel
	Spool torch		Remote connected indicator
	Settings		Cooler connected indicator

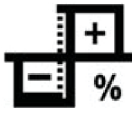
ICON	MEANING	ICON	MEANING
	2T, Trigger ON/OFF	<b>V</b>	Volts
	4T, Trigger Hold/Lock		User manual
<b>A</b>	Amps		Material thickness indication
	Arc force		Voltage trim indication
	Downslope time		Advanced Settings
	Hot start		Basic Settings
	Arc dynamics		Language selection
	Memory		Stick electrode choice
	Upslope time		Unit of Measure
.8 mm (.030") 	Wire diameter		Concave bead profile
	DC TIG/GTAW		Convex bead profile



ICON	MEANING	ICON	MEANING
	AC TIG/GTAW		Pulse
	HF On/Off		Pulse On/Off
	PPS		Background current
	Peak Time		Balance
	Offset		Frequency
	Retrieve		Erase

## 6.18 DC TIG/GTAW Pulse

DC TIG/GTAW Pulse welding is used primarily on thin metals but can also be used on thicker material based on the application. Pulsing allows the user to control the amount of heat input to the work piece. Pulse gives user far more control over the welding process without compromising the strength and integrity of the weld and helps in having a smooth and clean weld.

### Basic Mode:

In basic DC TIG/GTAW Pulse mode, the default settings are: Background Current 50%, Pulse Peak Time 50% and Pulses per Second: 2. User will not be able to adjust these Pulse parameters, in order to adjust these parameters user has to go to advanced mode. Below picture illustration shows the navigation/setup of DC TIG/GTAW Pulse in basic mode (A-B-C-D).

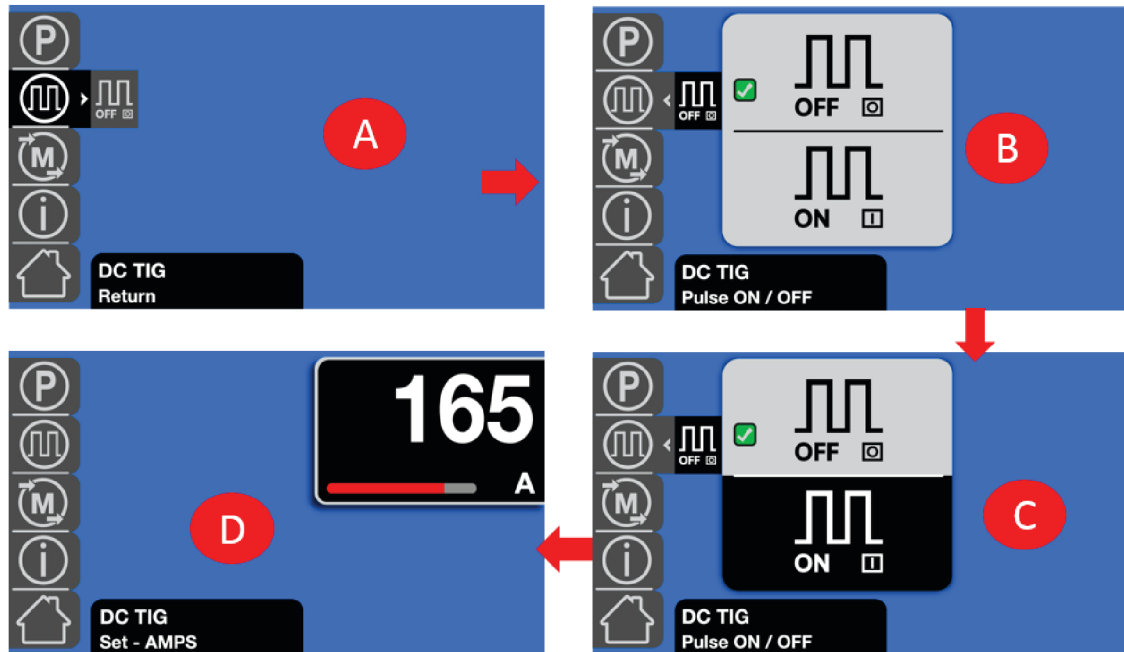

### Advanced Mode:

In advanced mode, the user has the ability to adjust the DC TIG/GTAW Pulse settings as explained below.

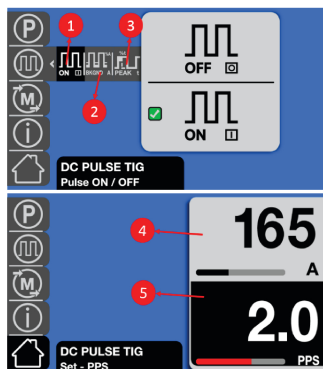

1. Pulse ON/OFF
2. Background current (%)
3. Peak Time (%)
4. Peak/Set Amperage indication
5. PPS indication

**Background current (%):** Background Current is the set point of the current at which the DC TIG/GTAW Pulse waveform achieves. The background current is adjusted as a percentage of peak current in the pulse menu. Can be adjusted between 1 and 99 %.

**Peak Time (%):** The peak time is the time at which the DC TIG/GTAW Pulse waveform is at peak current. Peak time is adjusted as a percentage of a given pulse. Can be adjusted between 1 and 99 %.

**Peak/Set Current (A):** The peak current is set by using the Upper encoder. Can be adjusted between 5 and 205 A.

**PPS (Pulses Per Second):** The rate at which DC TIG/GTAW Pulse current toggles between peak current and background current is set by using the Lower encoder. Can be adjusted between 0.1 and 500.

Below picture illustration shows the navigation/setup of DC TIG/GTAW Pulse in advanced mode (A-B-C-D-E-F-G-H-I-J).

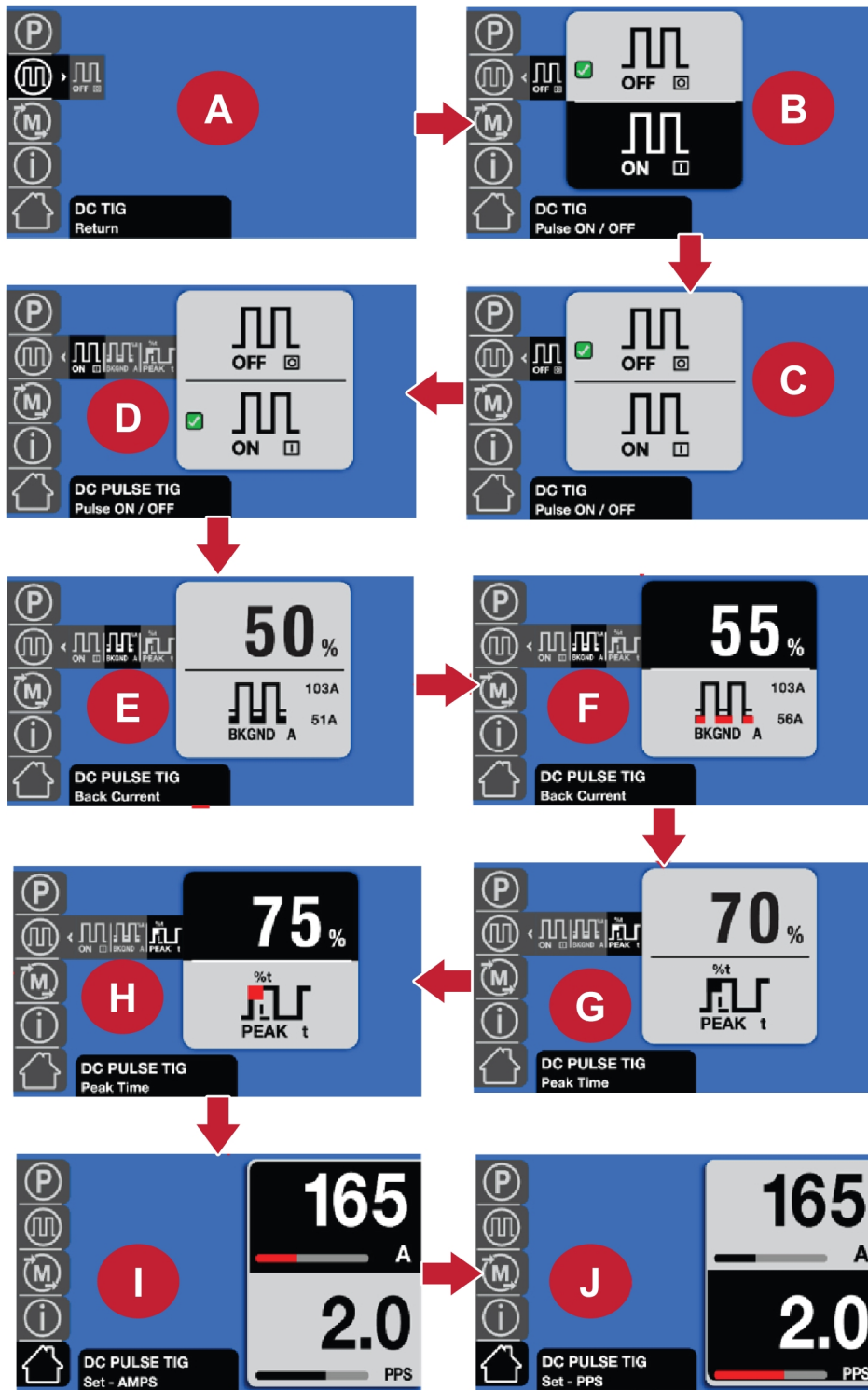

Below picture illustration shows an example of DC TIG/GTAW output current ideal waveforms in Basic and Advanced modes.

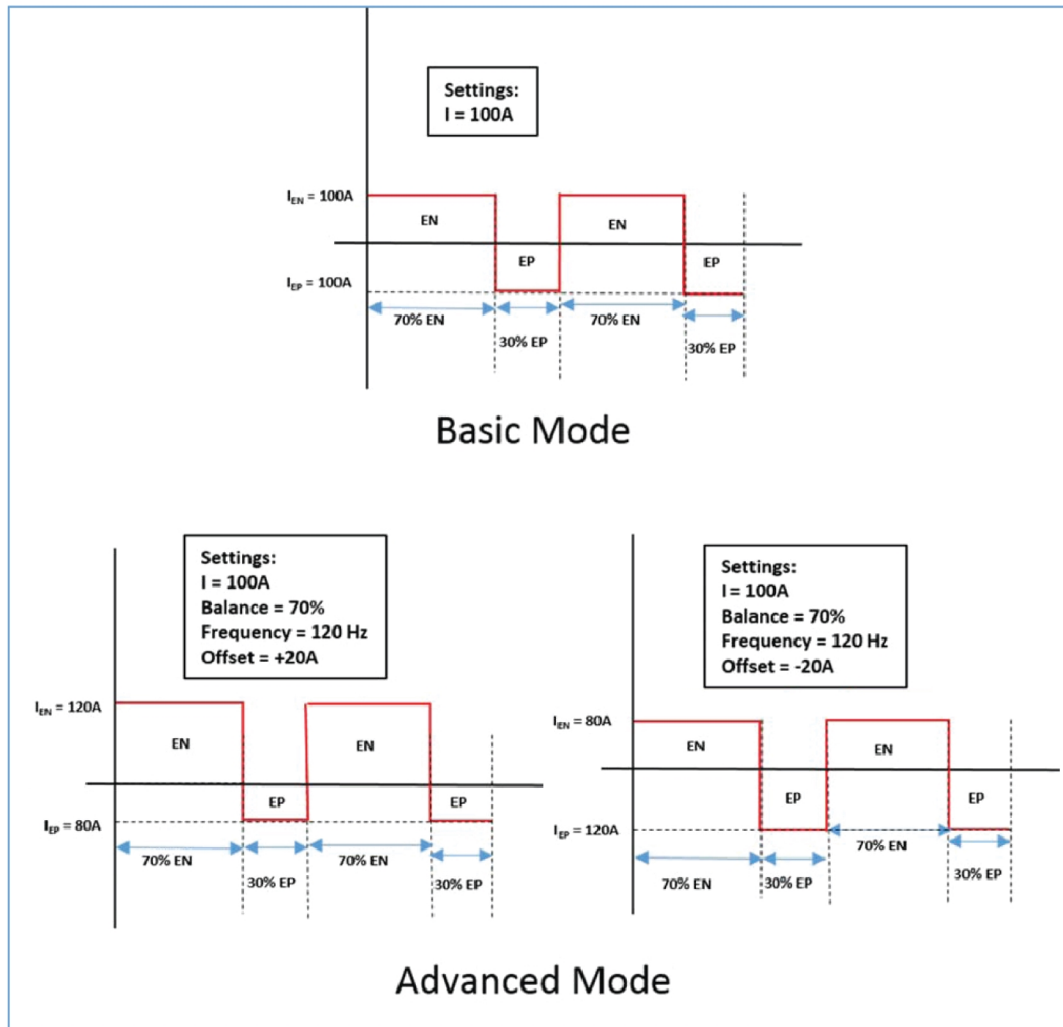

## 6.19 AC TIG/GTAW Welding

AC TIG/GTAW Welding is used mainly for non-ferrous materials like aluminum. In AC TIG/GTAW Welding the output current and polarity is switched between Electrode Positive (EP) and Electrode Negative (EN). In Rebel EMP 205ic AC/DC the switching of output polarity ranges from 25 – 400 Hz. EN polarity provides the welding action and EP polarity provides cleaning action.

### Basic Mode:

In basic mode AC TIG/GTAW has default settings as Pre-Flow = 0.8 sec, Post-Flow = 8 sec, Up-Slope = 0.5 sec, Down-Slope = 0.5 sec, Offset = 0, MIN = 10A, Frequency = 120 Hz, and Balance = 70%. User will not be able to adjust these parameters, in order to adjust these parameters user has to be in advanced mode.

### Advanced Mode:

In advanced mode user has the ability to adjust the AC TIG/GTAW settings as explained below.

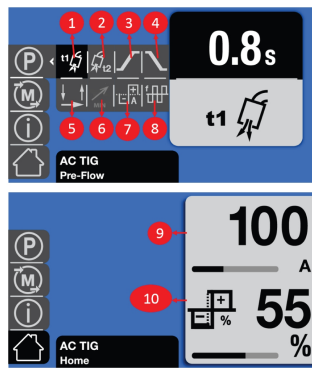

1. Pre-Flow Time selection
2. Post-Flow Time selection
3. Up-Slope Time selection
4. Down-Slope Time selection
5. 2T/4T Mode selection
6. Remote Minimum Amperage selection
7. Offset Amperage selection
8. AC Frequency selection
9. Amperage indication
10. Balance indication

**Remote Minimum Amperage:** Remote Minimum Amperage is used when a remote/foot control is used. The default value is 10A, user can adjust this value up to establish the lower limit of the remote/foot control.

**Up-Slope and Down-Slope Time** is adjustable only when there is no remote amperage control accessory being used.

**Frequency (Hz):** Frequency is the number of times the AC TIG / GTAW amperage switches between EP and EN in one second. Frequency in Rebel EMP 205ic AC/DC machine varies from 25 – 400 Hz with a default value of 120 Hz. Frequency helps in narrowing the weld bead and focus the arc. Higher frequencies narrows the weld bead, has more focused arc and increases the arc stability. For example the arc cone is much tighter at 400 Hz and focused at the same spot the tungsten electrode is pointing than the arc cone operating at 60 Hz.

**Balance (%):** Main Screen and lower right encoder is used to adjust the Balance (%) in AC TIG/GTAW advanced mode. Balance lets you control the arc width, heat, and cleaning action etc.

Benefits of increasing the balance (i.e., increasing the EN portion of the AC TIG / GTAW waveform):

- Achieve greater penetration
- Helps in increasing travel speeds
- Helps in narrowing the weld bead
- Helps in increasing the tungsten electrode life and reduces balling action
- Reduces the size of etched zone for improved cosmetics

Benefits of decreasing the balance (i.e., increasing the EP portion of the AC TIG/GTAW waveform):

- Better cleaning action to remove heavier oxidation on the work piece
- Minimizes penetration which help prevent burn-through on thin materials
- Widens the bead profile and helps in catching both sides of the joint



**NOTE!**

Decreasing the balance to a lower value at a particular weld current will have more balling action on the tungsten, which will reduce the tungsten electrode life and may lose arc stability.

**Offset (A):** Offset feature in AC TIG/GTAW is used to vary the EP or EN currents to have better cleaning or better penetration respectively without adjusting the balance and/or user set current. Offset gives the user ability to have a narrower bead with deeper penetration and no visible cleaning action or wider bead with less penetration and clear visible cleaning action based on which direction the Offset is adjusted.

In advanced AC TIG/GTAW mode, the user can adjust the Offset parameter which will range from - (UserSetCurrent – MIN) to + (UserSetCurrent – MIN). When using a foot pedal, the set value of MIN current affects the usable Offset range. Example, if UserSetCurrent is set to 104 A then the Offset adjustable range is from -94 A to +94 A, because MIN current is 10 A and adding 10 A to 94 A results in 104.

Another example; in the case of Offset set to +15 A with a user set current of 104 A, the weld current drives to EP = 119 A and EN = 89 A as shown in the pictures below.

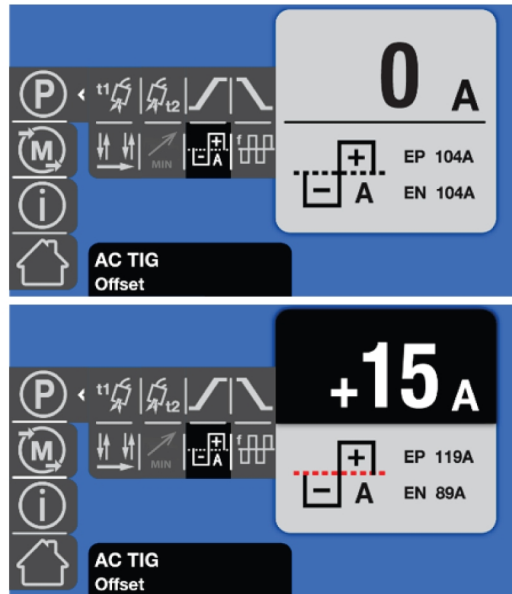

Below picture illustration shows the navigation/setup of AC TIG/GTAW Welding in advanced mode (A-B-C-D-E-F-G-H-I-J-K).

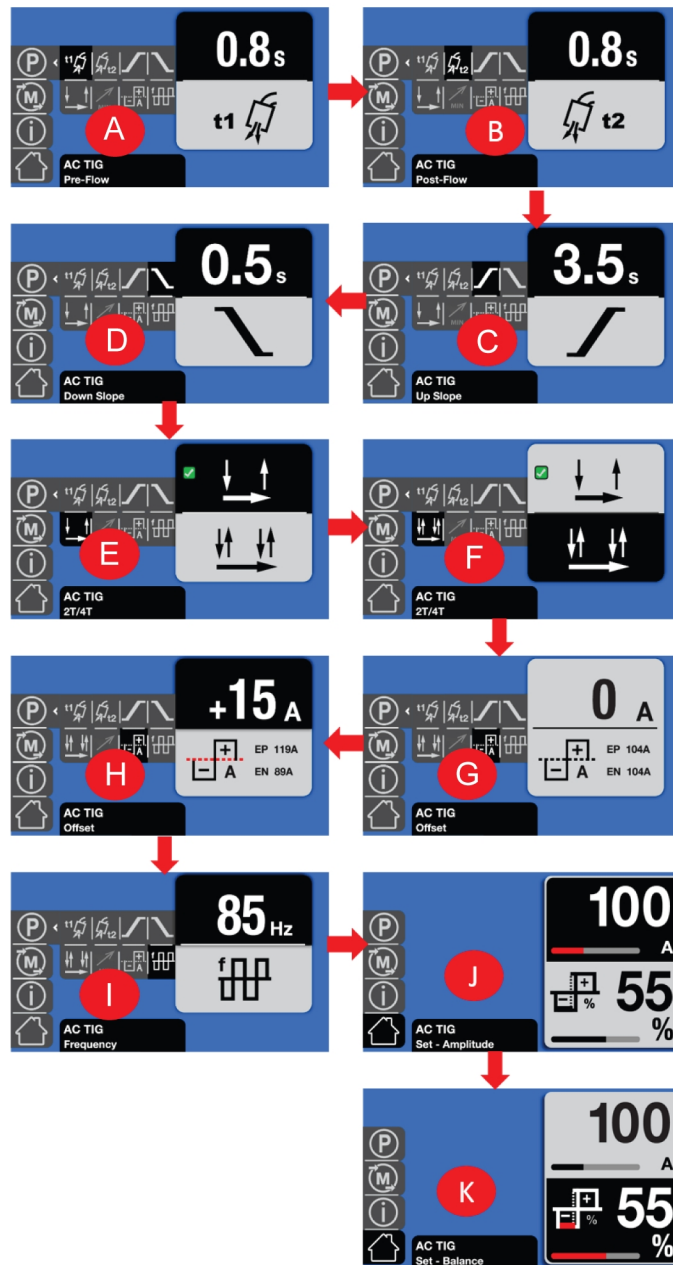

Below picture illustration shows an example of AC TIG/GTAW output current ideal waveforms in Basic and Advanced modes.

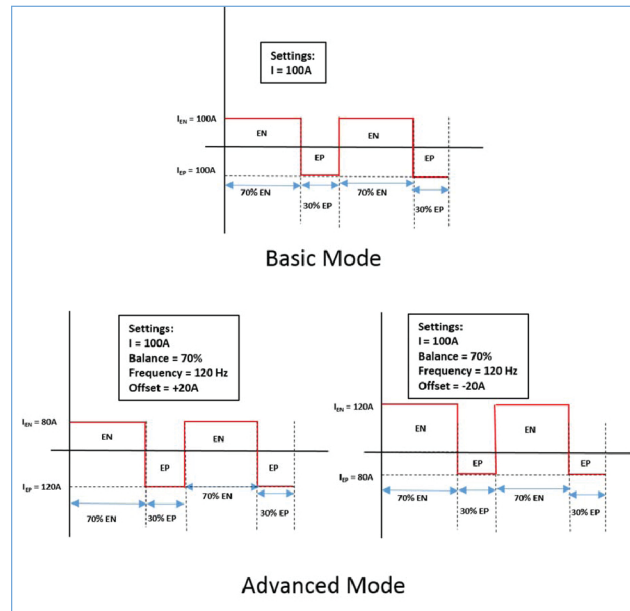

## 6.20 Lift TIG / GTAW welding

The trigger is used and current flows when lifting away the electrode to strike it.

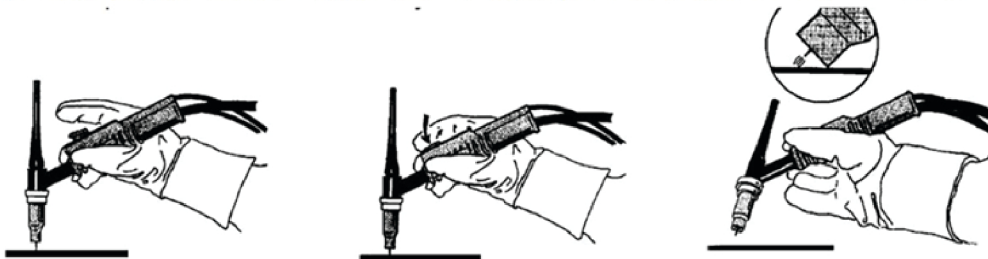

### 2-stroke and 4-stroke welding process illustrated



#### 2-stroke

In 2-stroke mode, press the TIG/GTAW torch trigger switch (1) to start the shielding gas flow and initiate the arc. The current slopes up to the set current value. Release the trigger switch (2) to start the slope down current and terminate the arc. The shielding gas will continue to flow in order to protect the weld and the tungsten electrode.

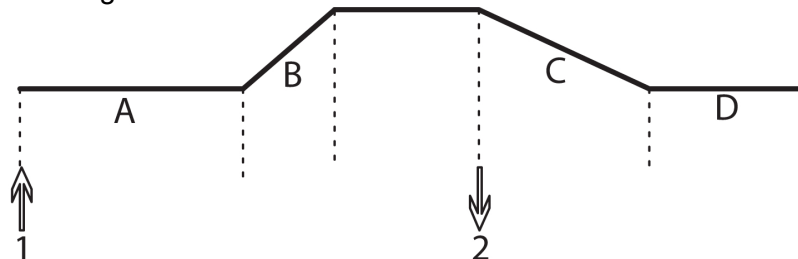

- A = Gas pre flow/arc start
- B = Slope up
- C = Slope down/arc end
- D = Gas post-flow



**4-stroke**

In 4-stroke mode, press the TIG / GTAW torch trigger switch (1) to start shielding gas flow and initiate the arc at a pilot level. Release the trigger switch (2) to slope up the current to the set current value. To stop the welding, press the trigger switch again (3). The current will slope down to the pilot level again. Release the trigger switch (4) to terminate the arc. The shielding gas will continue to flow in order to protect the weld and the tungsten electrode.

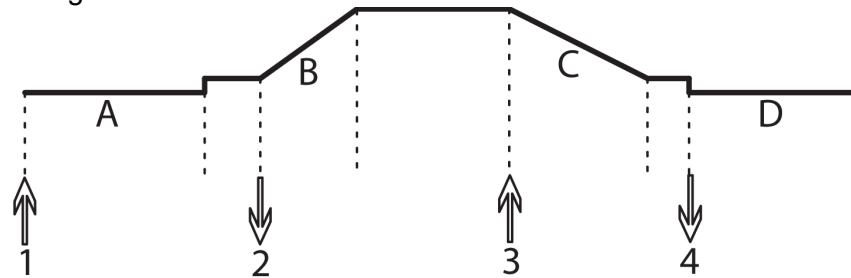

A = Gas pre-flow

B = Slope up

C = Slope down

D = Gas post-flow

## 7 MAINTENANCE



### WARNING!

Disconnect power before performing maintenance.



### CAUTION!

Only persons with the appropriate electrical knowledge (authorized personnel) may remove the cover of this product or carry out service, maintenance or repair.



### CAUTION!

The product is covered by the manufacturer's warranty. Any attempt to carry out repair work by non-authorized service centers will invalidate the warranty.



### CAUTION!

Before each use, make sure:

The torch body and torch cable and leads are not damaged.

The contact tip on the torch is not damaged.

The nozzle on the torch is clean and does not contain any debris.



### NOTE!

Perform maintenance more often during severe dusty conditions.







### NOTE!

There are no user serviceable parts inside of the power supply side of the unit. Any need for service on the electronics/electrical-power side should be referred to the nearest ESAB service center.

### 7.1 Routine maintenance

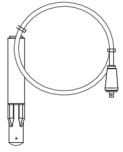
#### Maintenance schedule during normal conditions:

Interval	Area to maintain		
Every 3 months	 Clean or replace unreadable labels.	 Clean weld terminals.	 Check or replace weld cables.
Every 6 months	 Clean inside equipment.		

## 7.2 Wire-feeder assembly maintenance

General good practice is to perform this procedure each time a wire bobbin is replaced.

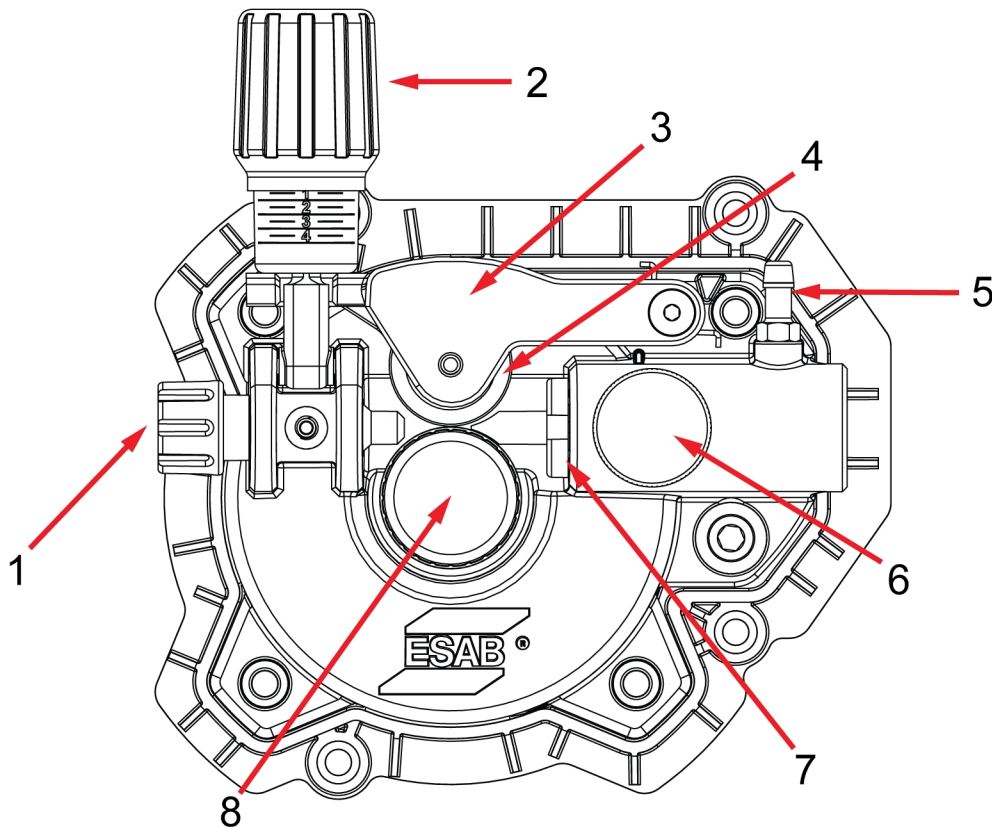

### Wire-feed assembly parts

- |                     |   |
|---------------------|---|
| 1. Inlet wire guide | 5. Gas inlet                              |
| 2. Tension knob     | 6. MIG/MAG/GMAW torch locking knob        |
| 3. Pressure arm     | 7. Outlet wire guide                      |
| 4. Pressure roller  | 8. Wire feed roller (behind locking knob) |

### 7.2.1 Wire-feeder assembly cleaning



#### **WARNING!**

Always use hand and eye protection when cleaning.

1. Disconnect the electrical power from the unit.
2. Open the cover on the wire-bobbin side of the unit.
3. Before moving the tension knob: note its numerical setting as indicated on its body right below the handle. Record this number to reset the tension in its approximate range.
4. Release the tension from the pressure rollers by turning the tension knob on the tension arm counter-clockwise enough to pull it up (out of its detent slot) and then toward you. The tension arm will spring-up as soon as the tension arm is released.
5. Using either soft-bristle brush or use a forced air source (max. 5 bar) to remove all debris which may have accumulated in this space.
6. Inspect if the input wire-feed guides and the feed rollers for wear and need replacement.



#### **NOTE!**

When removing the roller be careful **not** to lose the drive-shaft key on the motor shaft.

7. Clean the wire-feed roller with a soft brush.
8. Clean the pressure roller attached to the tension arm with a soft brush.
9. Close the tension arm on to the wire in its groove on the wire-feed rollers.



**NOTE!**

Verify that the wire is in the correct groove and not floating out of the groove on the roller surface.

10. Visually verify that the wire appears as a straight line through the entire wire-feed assembly.



**NOTE!**

The bobbin may be turned counter-clockwise to take up any slack. Do this only AFTER step 12 because the tension on the wire is the only force preventing the movement of the wire at the torch tip.

11. Visually verify that the wire protrudes per specification at the torch tip and has not been pulled into the torch head.
12. Adjust the wire-feed pressure by adjusting the tension on the wire at the wire-feed rollers by turning the tension knob.
13. Close the cover on the wire-bobbin side of the unit.

### 7.3 Rebel EMP 205ic AC/DC power side maintenance



**NOTE!**

There are no user-serviceable parts on the power-side. In dusty environments, the power-side should be checked periodically for any dust/debris accumulation because of the fan forced-air cooling used on this side.

Any maintenance on this side should be done by an authorized ESAB service technician.

## **7.4 Torch liner maintenance**

Refer to MIG/MAG/GMAW torch instruction manual for replacing standard steel torch conduit liner with a Teflon torch conduit liner.

### **7.4.1 Torch liner cleaning**

1. Disconnect the power source from the power supply.
2. Disconnect the torch assembly from the unit.
3. Remove the wire from the torch wire-liner by pulling the wire out from the torch wire-liner.
4. Remove the liner from the torch and inspect it for damage or kinks. Clean the liner by blowing compressed air (max. 5 bar) through the end of the liner that was mounted closest to the unit.
5. Re-install the liner.
6. Re-install the wire through the wire-feed assembly until visible at the torch tip. Verify that the wire does correctly feed out of the torch.

## 8 TROUBLESHOOTING

### 8.1 Preliminary checks

Try these checks and inspections before sending for an authorized service technician.

**Before attempting to troubleshoot it is recommended to first perform a WELD DATA RESET (navigate to HOME/SETTING/RESET/WELD DATA RESET). A WELD DATA RESET of the system will restore the unit to its default welding condition. Performing this Reset will not lose any user stored memory values but will establish a baseline from which all troubleshooting should start. If the WELD DATA RESET is not successful it is recommended to perform a Factory Reset and repeat testing.**



#### CAUTION!

A Factory Reset will erase all user stored memory locations. If this does not correct the problem, follow the table where possible.

Type of fault	Corrective action
Porosity within the weld metal	<ul style="list-style-type: none"> <li>• Check gas bottle is not empty.</li> <li>• Check gas regulator is not closed.</li> <li>• Check gas inlet hose for leaks or blockage.</li> <li>• Check that the correct gas is connected and the correct gas flow is used.</li> <li>• Keep the distance between the MIG/MAG/GMAW torch nozzle and the work piece to a minimum.</li> <li>• Do not work in areas where drafts, which would disburse the shielding gas.</li> <li>• Make sure the work piece is clean, with no oil or grease on the surface, before welding.</li> </ul>
Wire feeding problems	<ul style="list-style-type: none"> <li>• Make sure the wire spool brake is adjusted correctly.</li> <li>• Make sure the feed roller is correct size and not worn.</li> <li>• Make sure the correct pressure is set on the feed rollers.</li> <li>• Make sure the proper direction of travel is set based on the wire type.</li> <li>• Make sure the correct contact tip is used and it is not worn.</li> <li>• Make sure the liner is the right size and type for the wire.</li> <li>• Make sure the liner is not bent so that friction is caused between the liner and the wire.</li> </ul>
MIG/MAG/GMAW/FC AW welding problems	<ul style="list-style-type: none"> <li>• Make sure the correct polarity is being used for the type of wire.</li> <li>• Replace contact tip if there are signs of excessive wear or significant spatter build up that cannot be removed.</li> <li>• Make sure the correct shielding gas, gas flow, voltage, welding current, travel speed and MIG/MAG/GMAW torch angle is used.</li> <li>• Make sure the work lead has proper contact with the work piece.</li> </ul>
MMA/Stick/SMAW basic welding problems	<ul style="list-style-type: none"> <li>• Make sure you are using the correct polarity. The electrode holder is usually connected to the positive polarity and the work lead to the negative polarity. Consult the electrode data sheet.</li> </ul>

Type of fault	Corrective action
TIG / GTAW welding problems	<ul style="list-style-type: none"> <li>• Make sure the TIG/GTAW torch is connected to the power source: Connect the TIG/GTAW torch to the negative [-] welding terminal. Connect the welding ground cable to the positive [+] welding terminal.</li> <li>• Use 100% Argon gas for TIG/GTAW welding.</li> <li>• Make sure the regulator/flow meter is connected to the gas bottle.</li> <li>• Make sure the gas hose for the TIG/GTAW torch is connected to the gas outlet connector on the front of the power source.</li> <li>• Make sure the work clamp has proper contact with the workpiece.</li> <li>• Make sure the gas bottle is opened and check the gas flow rate on the regulator/flow meter. The flow rate should be between 10 – 25 CFH (4.7 – 11.8 l/min).</li> <li>• Make sure the power source is turned on and TIG / GTAW welding process is selected.</li> <li>• Make sure all connections are tight and leak-free.</li> </ul>
No power/No arc	<ul style="list-style-type: none"> <li>• Check that the input mains switch is turned on.</li> <li>• Check if a temperature fault is shown on display.</li> <li>• Check if system breaker is tripped.</li> <li>• Check that the input power, welding and return cables are correctly connected.</li> <li>• Check that the correct current value is set.</li> <li>• Check the input mains fuses/breakers.</li> </ul>
The overheating protection trips frequently.	<ul style="list-style-type: none"> <li>• Make sure that you have not exceeded the recommended duty cycle for the weld current being used.</li> <li>• Make sure the air inlets or outlets are not blocked.</li> <li>• Make sure fans are operating when welding.</li> </ul>

## 8.2 User interface error codes

The following table exhibits error codes that may appear to assist in troubleshooting.

Severity Level Meaning:

- **(C)** Critical Service Required - Unit not functional or locked, not recoverable
- **(NC)** Non-Critical - Service may be desired - unit functional with limited performance
- **(W)** Warning - Unit functional and will recover on its own

Error Code	Severity Level	Functional Circuit Failure Explanation
001	W	PFC Heatsink, IGBT Heatsink or Main transformer has overheated >185 °F (85 °C).
002	W	Output diode Temperature fault, Analog temperature sensor.
003	W/C	<b>Warning</b> - If occurred during load/arc-start, cause is due to low input AC volts - Err009 <b>Critical</b> - If occurred at power-up under no-load condition. DC Bus (400 V) fault droop under load, PFC not supplying 400 V to inverter.
004	C	Output voltage is above VRD levels when VRD switch is active.
005 – 007		(reserved)
008	C	OCV error, Output voltage not sensed at Control Board CN1 as expected
009	W	Low Voltage Error, AC Mains voltage is less than 108 V AC, this could trip Err 003
010		(reserved)
011	C	User has attempted a parameter or factory reset, and this was not confirmed by the system.
012	C	Communication Link Down, no communication between UI and Ctrl PCB at CN6
013	C	Low Internal Power Supply (IPS) Voltage Error, +24 V IPS is less than 22 V DC
014	C	Secondary Current Sensor output not detected at Control PCB CN18
015	C	Communication Link Down, no communication between Ctrl PCB at CN14 and AC DC inverter PCB at CN3
016	C	AC DC Inverter Temperature fault, Analog temperature sensor
017 – 019		(reserved)
020	C	No Image found in Flash
021	C	The image read from the flash is corrupted
022	NC	Failed two attempts of saving user memory to permanent memory in SPI Flash.
023	NC	Failed two attempts of recovering user memory permanent memory from SPI Flash.



## 9 ORDERING SPARE PARTS

---



### CAUTION!

Repair and electrical work should be performed by an authorized ESAB service technician. Use only ESAB original spare and wear parts.

The Rebel EMP 205ic AC/DC is designed and tested in accordance with **international standards ANSI/IEC 60974-1, 60974-5 & CAN/CSA-E60974-1, E60974-5**. It is the obligation of the authorized service center carrying out the service or repair work to ensure that the product still conforms to the aforementioned standards.

Spare parts and wear parts can be ordered through your nearest ESAB dealer, see the back cover of this document. When ordering, please state product type, serial number, designation and spare part number in accordance with the spare parts list. This facilitates dispatch and ensures correct delivery.

# DIAGRAM

Functional block diagram

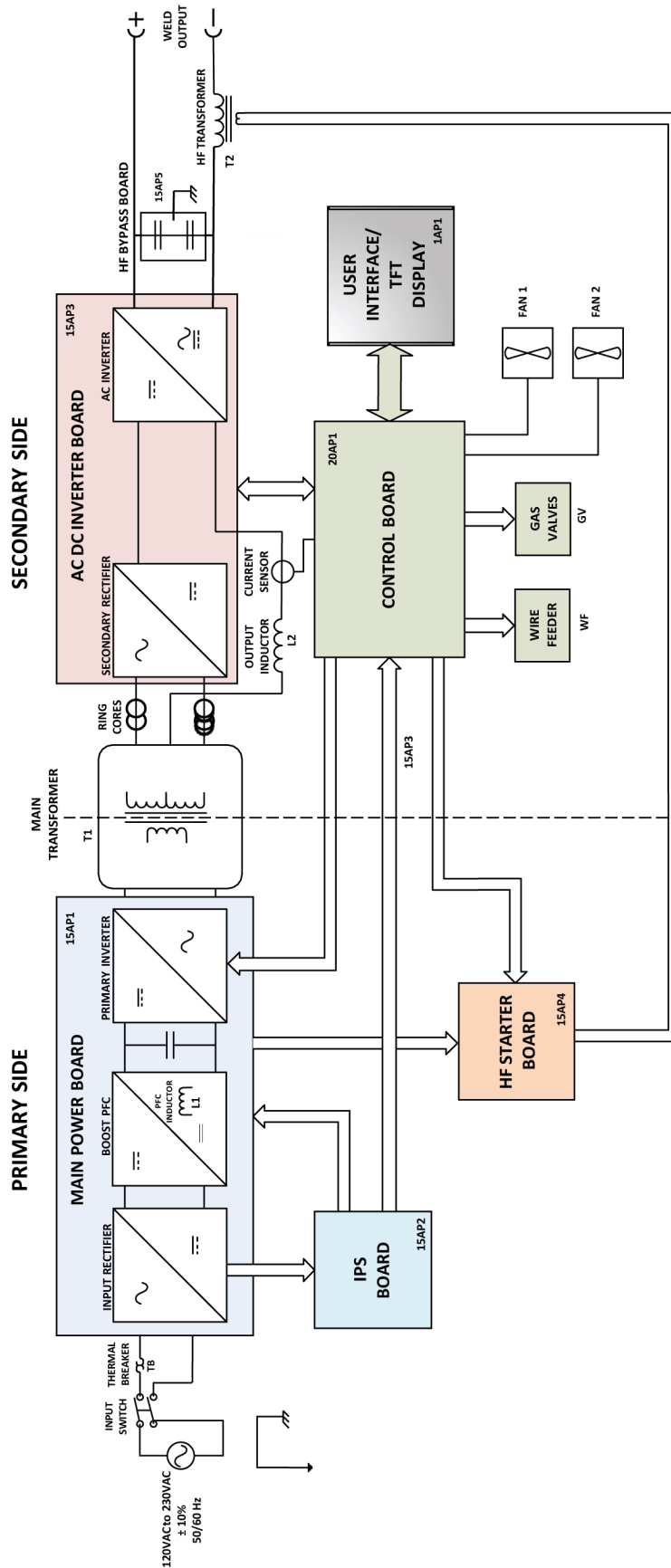

## ORDERING NUMBERS

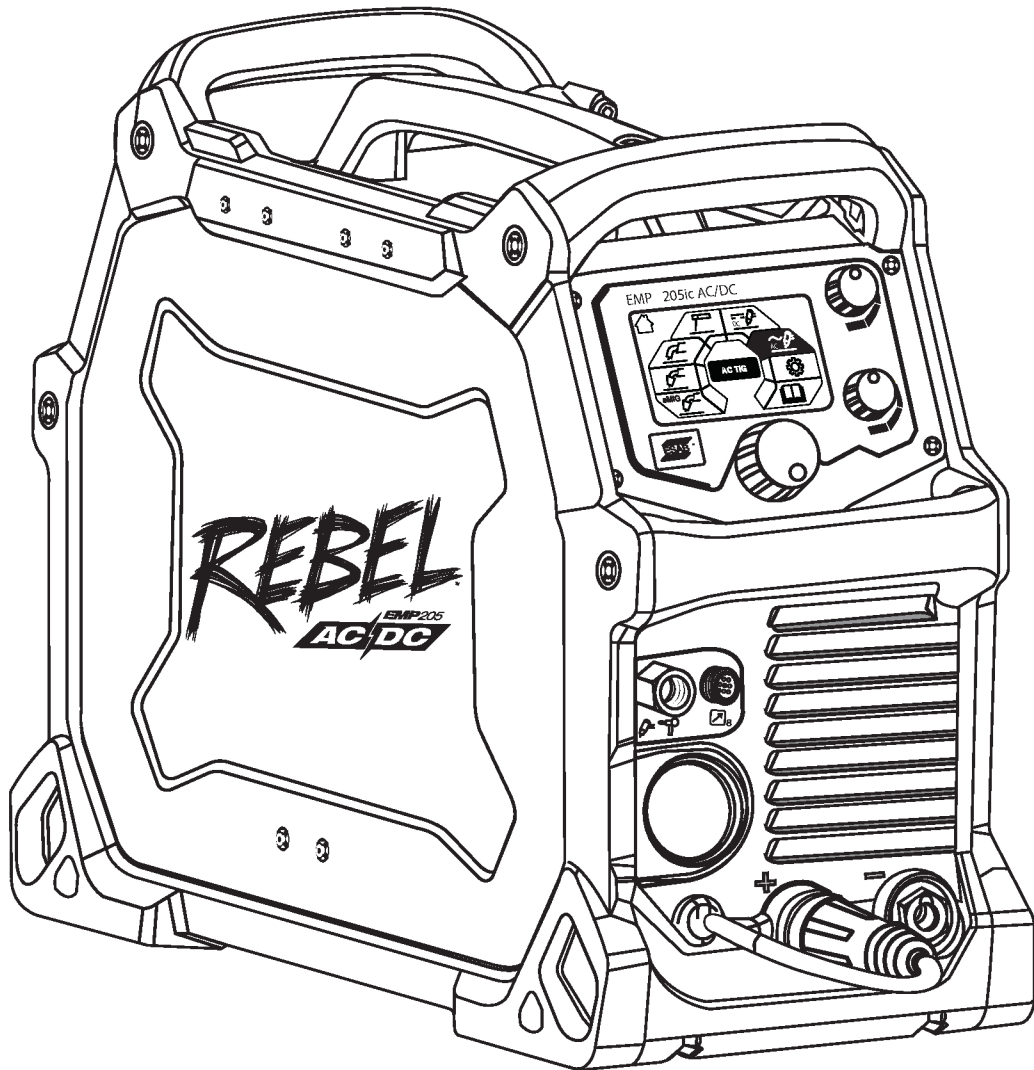

Ordering no.	Description	Note
0558 102 553	Rebel EMP 205ic AC/DC	Bobbin size 4–8 in. (100–200 mm)
0463 661 001	Spare Parts List	

## WEAR PARTS

Certain mechanical parts on the wire-feed assembly are subject to more frequent use hence may wear more frequently. These are exhibited here.

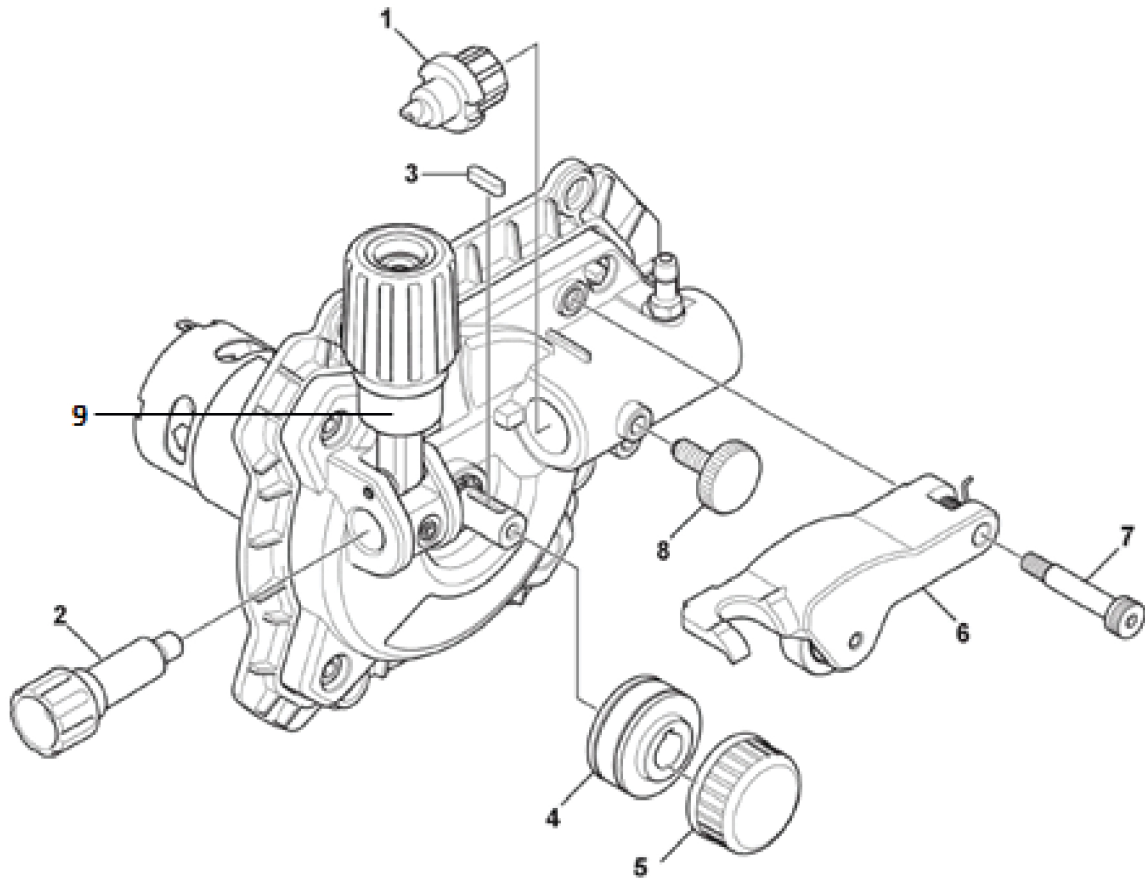

Item	Ordering no.	Description	Wire type	Wire dimensions
1	0558 102 326	Wire outlet guide	Fe/SS/Flux	0.030" (0.8 mm) 0.035" (0.9 mm) 0.045" (1.2 mm)
1	0558 102 327	Wire outlet guide	Fe/SS	0.024" (0.6 mm)
2	0558 102 328	Wire inlet guide	Fe/SS/Flux	0.024" (0.6 mm) 0.030" (0.8 mm) 0.035" (0.9 mm) 0.045" (1.2 mm)
3	0558 102 334	Key-drive shaft	N/A	N/A
4	W4014800	Drive roll "V" groove	Fe/SS	0.023" (0.6 mm) 0.035" (0.9 mm)
	7977036	Drive roll "V" groove	Fe/SS	0.024" (0.6 mm) 0.030" (0.8 mm)
	7977732	Drive roll "Flux cored V" groove	Fe/SS	0.030" (0.8 mm) 0.035" (0.9 mm)
5	0558 102 329	Locking knob	N/A	N/A

WEAR PARTS

---

<b>Item</b>	<b>Ordering no.</b>	<b>Description</b>	<b>Wire type</b>	<b>Wire dimensions</b>
6	0558 102 331	Pressure arm assembly	N/A	N/A
7	0558 102 331	Screw	N/A	N/A
8	0558 102 333	MIG torch locking knob	N/A	N/A

## ACCESSORIES

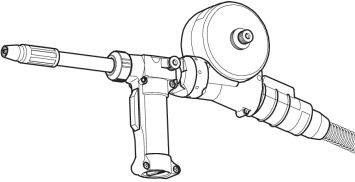
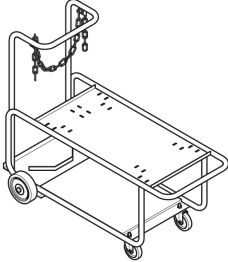
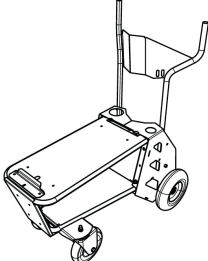
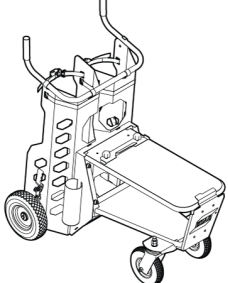
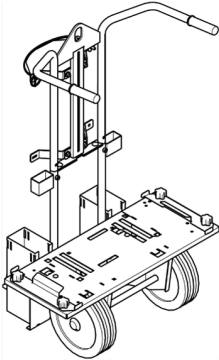
1027-1397	<p><b>Spool torch</b> 160 A, 12 ft (3.6 m), suits 4 in. (100 mm) spools</p>	
0558 102 325	<p><b>Basic utility cart</b> Accommodates maximum 7 in. (177.8 mm) diameter cylinder</p>	
0558 102 491	<p><b>Rebel single cylinder cart</b> Accommodates 1 × 9 in. (228.6 mm) diameter cylinder</p>	
0558 103 000	<p><b>Rebel dual cylinder cart</b> Accommodates maximum 9 in. diameter cylinder with accessory drawer and a parts storage box.</p>	
0700 300 872	<p><b>Rebel two wheel trolley</b></p>	

ACCESSORIES

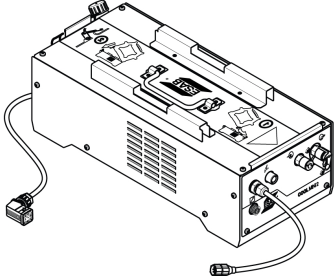
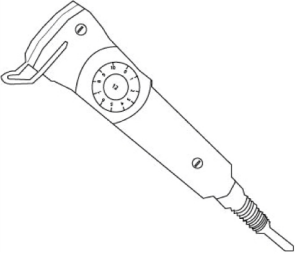
0447 888 880	<b>CoolMini 2 Cooler</b>	 A rectangular electronic cooler unit with a handle on top, ventilation grilles on the side, and various connectors and cables on the front panel.
0700 500 084	<b>MMA 4 Analogue remote control</b> including 33 ft. (10 m) cable and 8-pin connector	 A handheld remote control device with a circular dial on the side and a long, thin cable extending from the end.

## REPLACEMENTS PARTS

Item	Ordering no.	Denomination
1	1017-1338	Tweco® Fusion™ 180 A MIG gun, 10 ft (3 m)
2	0700 026 610	ESAB Heliarc SR-17 TIG Torch, gas-cooled, 12.5 ft (4 m)
3	0700 026 611	ESAB Heliarc SR-17 TIG Torch, gas-cooled, 25 ft (8 m)
4	0558 102 667	ESAB 200 A electrode holder & lead assembly, 13 ft (4 m), 2 in. (50 mm) dinse
5	WS200G10	Tweco® 200 A ground clamp & lead assembly, 10 ft (3 m), 2 in. (50 mm) dinse
6	0781 3657	Victor® Flow Meter with 10 ft (3 m) gas hose
7	W4014000	Power adapter (230 V – 120 V, 15 A) (US only)
8	0558 102 666	ESAB Foot Control, 15 ft (14,6 m), 8-pin male plug
9	0700 026 620	ESAB Heliarc SR-26 TIG Torch, gas-cooled, 12.5 ft (4 m)
10	0700 026 621	ESAB Heliarc SR-26 TIG Torch, gas-cooled, 25 ft (8 m)
11	0700 025 534	ESAB Heliarc SR-B 20 TIG Torch, water-cooled, 12.5 ft (4 m)
12	0700 025 535	ESAB Heliarc SR-B 20 TIG Torch, water-cooled, 25 ft (8 m)
13	0700 025 544	ESAB Heliarc SR-B 21 TIG Torch, water-cooled, 12.5 ft (4 m)
14	0700 025 545	ESAB Heliarc SR-B 21 TIG Torch, water-cooled, 25 ft (8 m)
15	1110-1308	Velocity contact tip, 0.023 in. (0.6 mm) Tweco® Fusion™ 180 A
16	1110-1309	Velocity contact tip, 0.030 in. (0.8 mm) Tweco® Fusion™ 180 A
17	1110-1310	Velocity contact tip, 0.035 in. (0.9 mm) Tweco® Fusion™ 180 A
18	1110-1312	Velocity contact tip, 0.045 in. (1.2 mm) Tweco® Fusion™ 180 A
19	1220-1206	Velocity nozzle, 3/8 in. ID, Tweco® Fusion™ 180 A
20	1220-1201	Velocity nozzle, 1/2 in. ID, Tweco® Fusion™ 180 A
21	1220-1203	Velocity nozzle, 5/8 in. ID, Tweco® Fusion™ 180 A
22	1220-1207	Velocity FCAW tip holder
23	1220-1208	Velocity FCAW tip holder insulator
24	1420-1140	Conduit/liner, Tweco® Fusion™ 180 A, 0.030/0.035 in. (0.8/0.9 mm), hard
25	1420-1123	Conduit/liner, Tweco® Fusion™ 180 A, 0.040/0.045 in. (1.0/1.2 mm), hard
26	1420-1003	Conduit/liner, Tweco® Fusion™ 180 A, 0.030/0.045 in. (0.8/1.2 mm), soft







# A WORLD OF PRODUCTS AND SOLUTIONS.



For contact information visit [esab.com](http://esab.com)

ESAB Corporation, 2800 Airport Road Denton, TX 76207, USA, Phone +1 800 378 8123

[manuals.esab.com](http://manuals.esab.com)

